



SECTION 4

STANDARD DRAWINGS
- - WATER FACILITIES - -
(OCTOBER 15TH, 2024)

SECTION 4

DWG #	STANDARD DRAWINGS – DOMESTIC WATER	Revision Date
W-1	Typical 3/4" Through 1" Water Service Installation	11/3/21
W-1A	3/4" & 1" Meter With RP Device	11/3/21
W-2	1.5" & 2" Water Service Installation	11/3/21
W-2A	1.5" & 2" Meter With RP Device	11/3/21
W-3	3" Through 6" Water Service	11/3/21
W-3A	3" Through 6" Water Service With RP Device	11/3/21
W-4	Concrete Thrust Blocks	5/24/17
W-5	Service Outlet Saddle	11/3/21
W-6	2" Blow Off Assembly	9/25/19
W-7	4" Blow Off Assembly (For Pressure Less Than 250 psi)	9/23/19
W-8	4" Blow Off Assembly (For Pressure 250 psi and Greater)	9/23/19
W-9	6" Fire Hydrant Assembly (For Pressure Less Than 250 psi)	5/9/24
W-10	6" Fire Hydrant Assembly (For Pressure 250 psi and Greater)	5/24/17
W-11	2" Automatic Air Release and Vacuum Relief Valve	10/18/23
W-12	4" and 6" Automatic Air Release and Vacuum Relief Valve	10/18/23
W-13	Standard Guard Post Installation	5/24/17
W-14	Water Pipeline Pipe Installation & Separation Requirements	5/24/17
W-15	Standard Cutoff Wall	12/16/20
W-16	Appurtenance Wall	5/24/17
W-17	Standard Cul-de-Sac Water Services	5/24/17
W-18	Three Valve Tee (Typical)	7/12/17
W-19	Valve Well Frame AND Valve Well Cover	11/3/21
W-20	Standard Pipe Zone and Trench Backfill	11/3/21
W-21	Trench Resurfacing	11/3/21
W-22	4" Fire Service / Notes	5/24/17
W-23	3" Fire Service / Notes	5/24/17
W-24	2" Fire Service / Notes	2/7/18
W-25	Water Sample Connection	2016
W-26	Concrete CAP – cover shallow pipe	11/3/21

NOTE:

REFER TO ABOVE LEGEND FOR MATERIAL CALL OUTS.

SEE NOTE 6

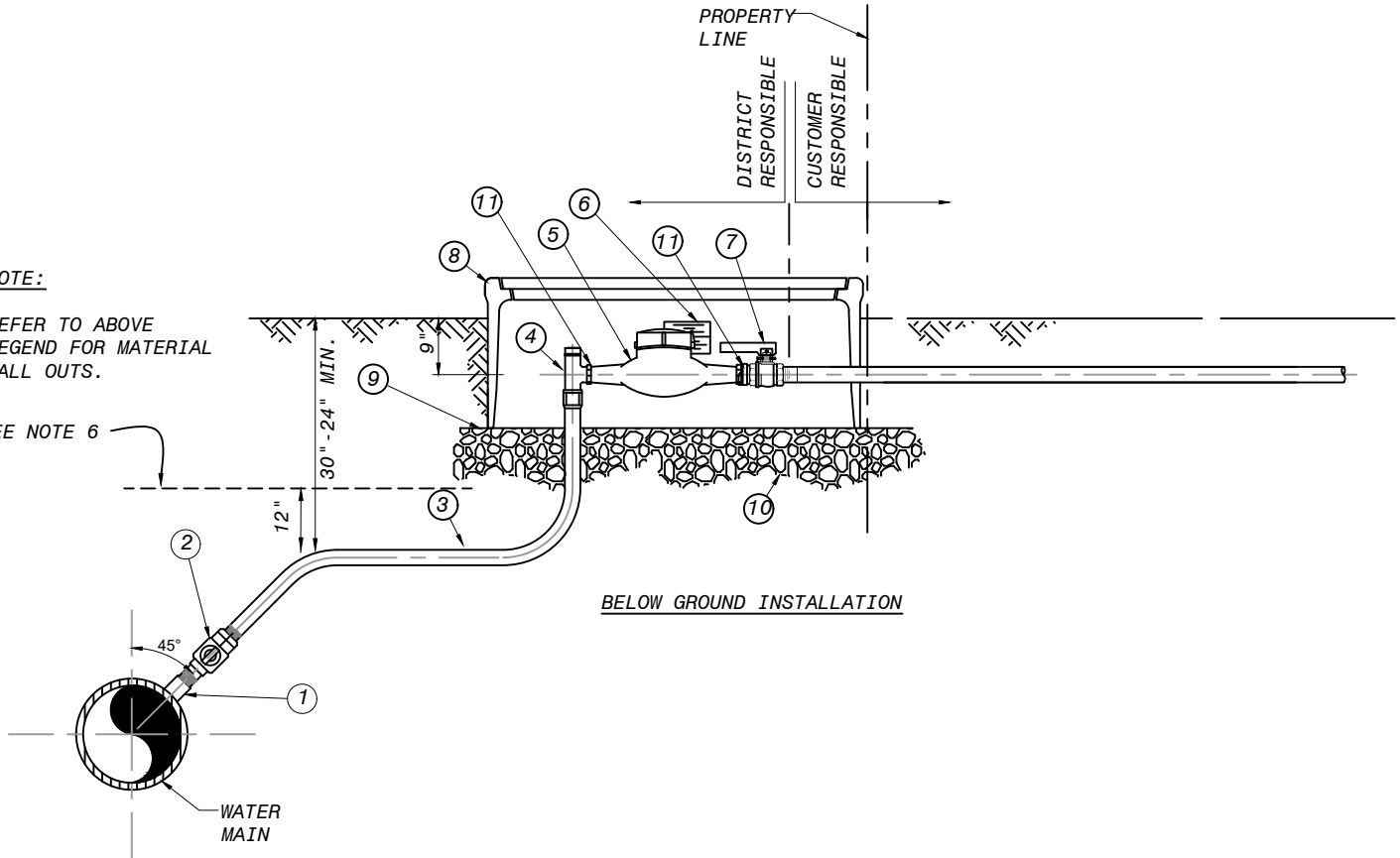

BELOW GROUND INSTALLATION

TYPICAL CONSTRUCTION NOTES:

1. REPAIR COATING ON PIPE TO COVER WELDED COUPLING AND REPAIR COUPLING AND MALE THREADS OF CORP STOP AFTER CONNECTING PIPE. SEE W-5.
2. APPLY BITUMASTIC COMPOUND TO COUPLING AND MALE THREADS OF CORP STOP AFTER CONNECTING TO A TAR/WRAPPED STEEL PIPE.
3. PIPE THREADS SHALL BE CLEAN, SHARP AND WRAPPED WITH A PIPE THREAD SEAL TAPE.
4. WHERE METER BOX IS LOCATED IN CONCRETE OR ASPHALT TRAFFIC AREAS, CONTACT DISTRICT FOR AN APPROVED CONCRETE METER BOX.
5. WRAP BURIED FACILITIES WITH 10 MIL CALPICO TAPE OR CONTINUOUS POLYETHYLENE SLEEVE ENCASMENT (6-MIL).
6. INSTALL BLUE UNDERGROUND WARNING TAPE, INDICATING "WATER PIPE", IN PIPE TRENCH 12" ABOVE PIPE.
7. SHALLOW SERVICE LINE INSTALLATIONS SHALL BE APPROVED BY D.E. PRIOR TO CONSTRUCTION.
8. 3/4" METER - 1" SERVICE LINE
1" METER - 1" SERVICE LINE
9. CUSTOMER IS RESPONSIBLE TO PROTECT PRIVATE FACILITIES AND TO SUPPLY PRESSURE REDUCING VALVE WHEN PRESSURE IS HIGH. REFER TO THE UNIFORM PLUMBING CODE AND PRIVATE ENGINEER REGARDING INSTALLATION OF A PRESSURE REGULATOR AFTER METER.

MATERIAL LIST

ITEM	QTY	MATERIAL	PART NO.
1		PER W-5: FORGED STEEL HALF-COUPLING, THREADED, CLASS 3000 WELDED TO PIPE WITH REINFORCING SADDLE (CML&C PIPE); OR DOUBLE STRAP, STAINLESS STEEL, TAPPING COLLAR (PVC OR DUCTILE IRON PIPE).	
2		THREADED CORP STOP, MIP x MIP THREAD BALL VALVE (T-HEAD ONLY), OR APPROVED EQUAL BY D.E.	J E-1943, J E-1956
3		CONTINUOUS TYPE "K" COPPER TUBING	SEE NOTE 8
4		ANGLE STOP: 180 deg METER SIZE 3/4" (1"X3/4") TURN, FIP X SWIVEL NUT METER SIZE 1" (1" X 1") AND LOCK WING.	JONES E-1527 JONES E-1527
5		WATER METER SUPPLIED BY DISTRICT	
6		ERT RADIO SUPPLIED AND/OR INSTALLED BY DISTRICT	
7		BRONZE BALL VALVE, JONES OR FORD WITH LOCKING WING AND BRASS HANDLE OR APPROVED EQUAL BY D.E. HANDLE: JONES - HB-34 AND FORD - J-2813	JONES E-1908W, FORD B13-332W, B13-444W-NL
8		HDPE PLASTIC METER BOX AND COVER, (GREEN) BRASS METER TAILS WITH GASKETS.	REG: 20"X26"
9		1/2" WIRE MESH 19 GAUGE, GALVANIZED COATING D, SET 1" BEYOND METER BOX DIMENSIONS	
10		6" BASE OF 3/4" ROCK	
11		USE FPU D APPROVED GASKET WASHERS. CLOTH INSERTED GASKET W/ FABRIC FINISH: 1/8" THICK	TRIPAC



Rev. Date	By	Approve
2/23/17	SMD	JB
11/3/21	SMD	AWC



TYPICAL 3/4" THRU 1" WATER SERVICE INSTALLATION

DRAWING NO.

W-1

K:\RECORD FILES\DISTRICT STANDARDS\DISTRICT DRAWINGS\WATER

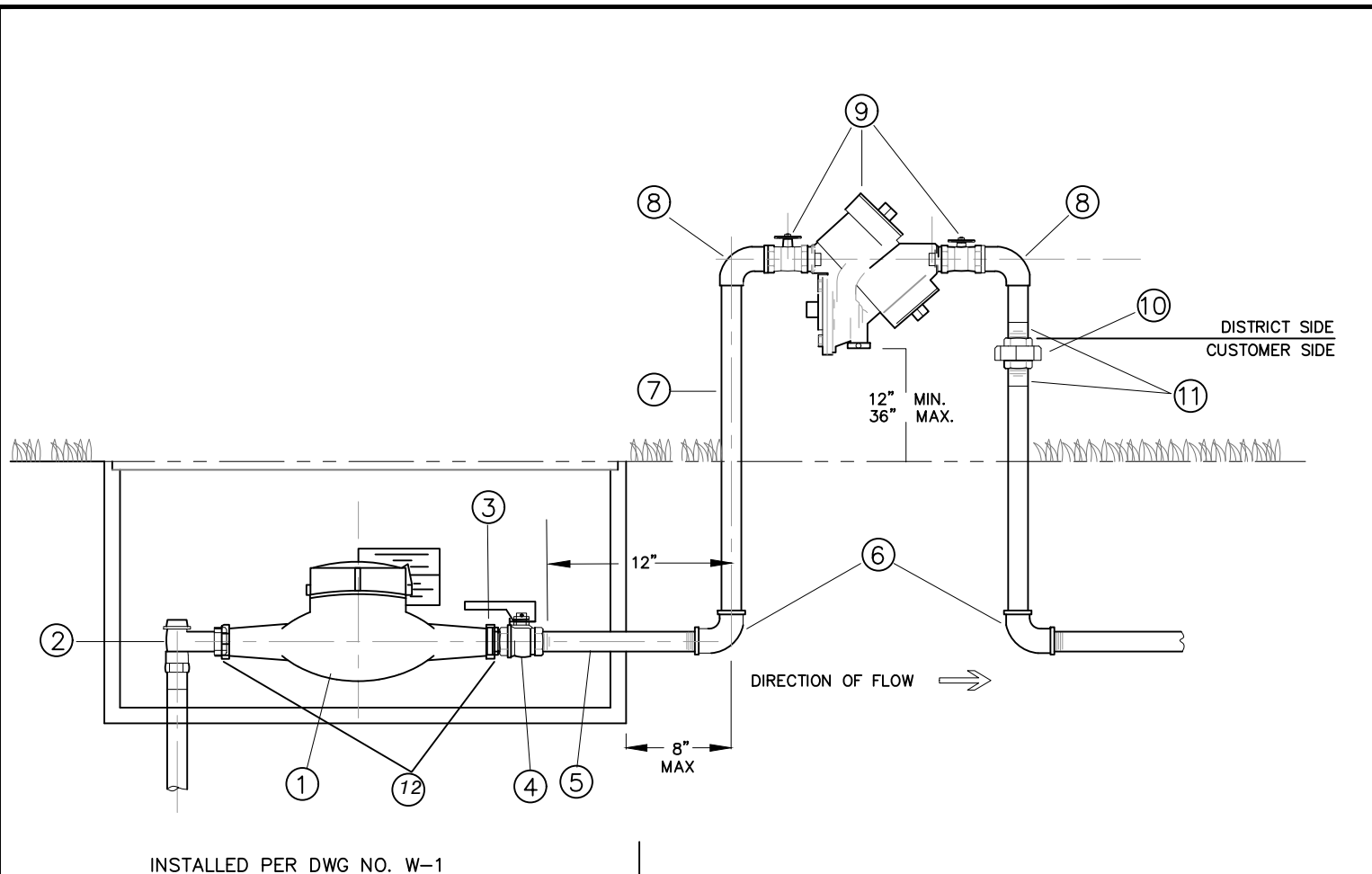

INSTALLED PER DWG NO. W-1

MATERIAL LIST

ITEM	QTY	PART TYPE	PART NO.
1	1	METER (SUPPLIED BY THE DISTRICT)	3/4" OR 1" METER
2	1	ANGLE STOP	JONES 1527, FIP
3	1	METER CONNECTION	MIP
4	1	BALL VALVE, BRASS, W/ LOCKING WING	E-1903W (W/BRASS HANDLE)
5	1	COPPER OR BRASS NIPPLE	(12" MAX. LENGTH)
6	2	90° EL	C X FIP 90
7	REQ'D	TYPE K HARD COPPER PIPE	TYPE K
8	2	90° EL	C X MIP 90
9	1	R.P. DEVICE WITH BALL VALVES	WILKINS 975XL
10	1	UNION, THREADED BRASS	FIP X FIP
11	2	ADAPTER	C X MIP ADAPTER
12	2	USE FPU D APPROVED GASKET WASHERS.	CLOTH INSERTED W/ FABRIC FINISH, 1/8" THICK

NOTE:

CUSTOMER IS RESPONSIBLE TO PROTECT PRIVATE FACILITIES AND TO SUPPLY PRESSURE REDUCING VALVE WHEN PRESSURE IS HIGH. REFER TO THE UNIFORM PLUMBING CODE AND PRIVATE ENGINEER REGARDING INSTALLATION OF A PRESSURE REGULATOR AFTER METER. MAXIMUM PRESSURE ALLOWED FOR R.P. DEVICES IS 175 PSI. CONTACT ENGINEERING TO DISCUSS IF STATIC PRESSURE AT METER IS OVER 175 PSI.

X:\RECORD FILES\DISTRICT STANDARDS\DRAWINGS\WATER



REV. DATE	BY	APP'V'D
2/23/17	SMD	JB
11/3/21	SMD	AWC

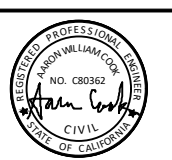

3/4" TO 1" METER WITH REDUCED PRESSURE BACKFLOW DEVICE

DRAWING NO.
W-1A

NOTE:

REFER TO MATERIAL LIST FOR MATERIAL CALL OUTS.

SEE NOTE 6

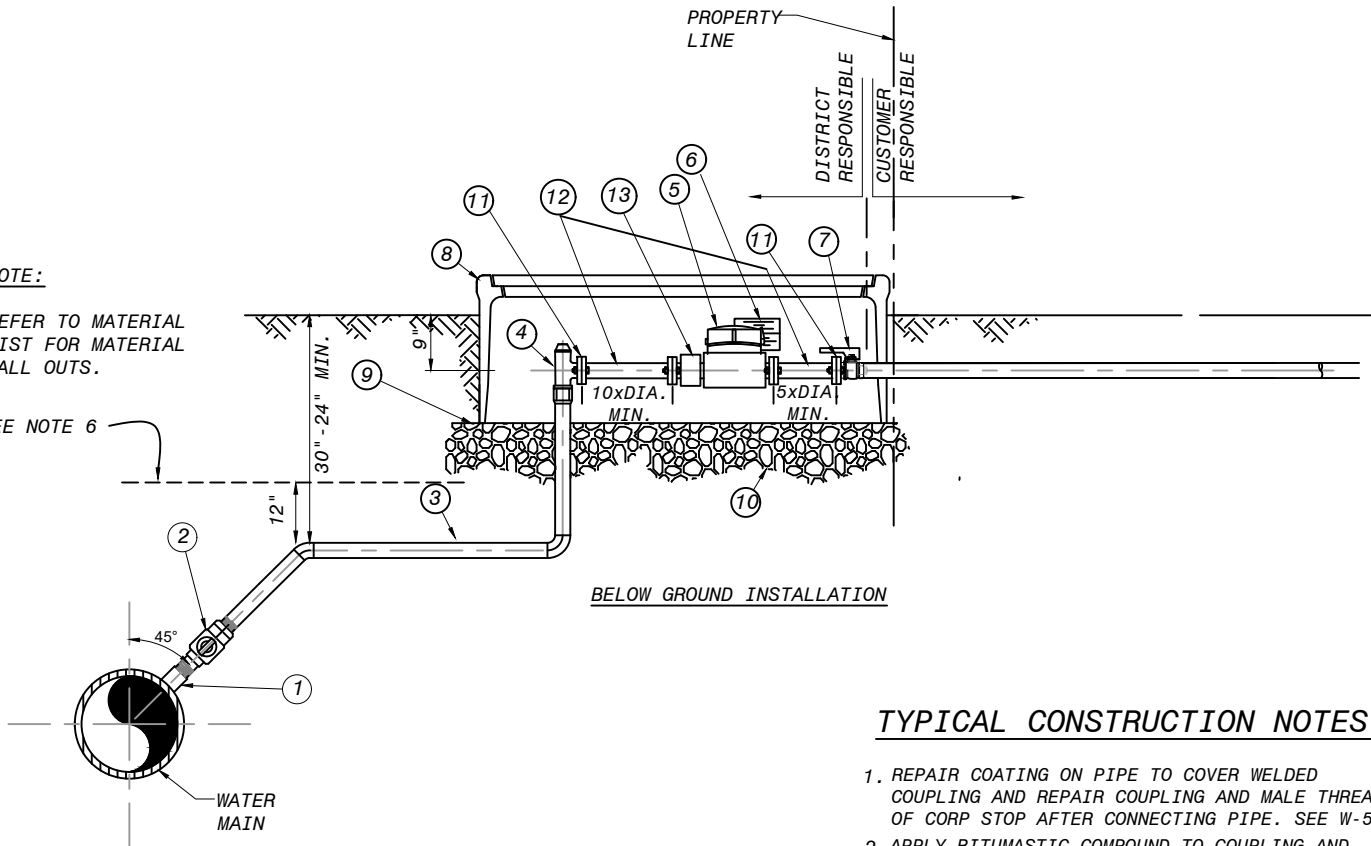

BELOW GROUND INSTALLATION

TYPICAL CONSTRUCTION NOTES:

1. REPAIR COATING ON PIPE TO COVER WELDED COUPLING AND REPAIR COUPLING AND MALE THREADS OF CORP STOP AFTER CONNECTING PIPE. SEE W-5.
2. APPLY BITUMASTIC COMPOUND TO COUPLING AND MALE THREADS OF CORP STOP AFTER CONNECTING TO A TAR/WRAPPED STEEL PIPE.
3. PIPE THREADS SHALL BE CLEAN, SHARP AND WRAPPED WITH A PIPE THREAD SEAL TAPE.
4. WHERE METER BOX IS LOCATED IN CONCRETE OR ASPHALT TRAFFIC AREAS, CONTACT DISTRICT FOR AN APPROVED CONCRETE METER BOX.
5. WRAP BURIED FACILITIES WITH 10 MIL CALPICO TAPE OR CONTINUOUS POLYETHYLENE SLEEVE ENCASEMENT (6-MIL).
6. INSTALL BLUE UNDERGROUND WARNING TAPE, INDICATING "WATER PIPE", IN PIPE TRENCH 12" ABOVE PIPE.
7. SHALLOW SERVICE LINE INSTALLATIONS SHALL BE APPROVED BY D.E. PRIOR TO CONSTRUCTION.
8. 1-1/2" METER - 1-1/2" COPPER SERVICE LINE
2" METER - 2" COPPER SERVICE LINE
9. ALL SOLDERED JOINTS SHALL BE PRESSURE TESTED AND INSPECTED PRIOR TO WRAPPING & BURIAL.
10. SERVICE LATERAL SHALL BE SLOPED (0.25° MINIMUM) TO ENSURE NO AIR ENTRAPMENT.
11. METER MAY BE SUPPLIED WITH BOLT ON PLATE STRAINER. IF STRAINER IS RELOCATED PRIOR TO UPSTREAM SPOOL, SPOOL LENGTH CAN BE REDUCED TO 5 X DIA. CONSULT DISTRICT ENGINEER FOR MORE INFORMATION.
12. CUSTOMER IS RESPONSIBLE TO PROTECT PRIVATE FACILITIES AND TO SUPPLY A PRESSURE REDUCING VALVE WHEN PRESSURE IS HIGH. REFER TO THE UNIFORM PLUMBING CODE AND PRIVATE ENGINEER REGARDING INSTALLATION OF A PRESSURE REGULATOR AFTER METER.

MATERIAL LIST

ITEM	QTY	MATERIAL	PART NO.
①		PER W-5: FORGED STEEL HALF-COUPLING, THREADED, CLASS 3000 WELDED TO PIPE WITH REINFORCING SADDLE (CML&C PIPE); OR DOUBLE STRAP, STAINLESS STEEL, TAPPING COLLAR (PVC OR DUCTILE IRON PIPE).	
②		THREADED CORP STOP, MIP x MIP THREAD BALL VALVE (T-HEAD ONLY), OR APPROVED EQUAL BY D.E.	J E-1943, J E-1956
③		TYPE "K" COPPER TUBING. W/45° AND 90° FITTINGS	SEE NOTES 8-10
④		ANGLE STOP: 180 deg TURN, FIP X FLG AND LOCK WING.	JONES E-1527F
⑤		WATER METER SUPPLIED BY DISTRICT	
⑥		ERT RADIO SUPPLIED AND/OR INSTALLED BY DISTRICT	
⑦		BRONZE BALL VALVE, JONES OR FORD WITH LOCKING WING AND BRASS HANDLE OR APPROVED EQUAL BY D.E. HANDLE: JONES - HB-34 AND FORD - J-2813	JONES E-1913W, FORD B13-332W, B13-444W-NL
⑧		HDPE PLASTIC METER BOX AND COVER, (GREEN) BRASS METER TAILS WITH GASKETS. BY METER SIZE:	1.5" : 36"X48" 2" : 36"X60"
⑨		1/2" WIRE MESH 19 GAUGE, GALVANIZED COATING D, SET BELOW AND 1" BEYOND METER BOX DIMENSIONS	
⑩		6" BASE OF 3/4" ROCK	
⑪		USE FPD APPROVED GASKET WASHERS. RUBBER FLANGED GASKETS W/ RAISED O-RING.	
⑫	2	FLANGED BRASS SPOOL. LENGTH DETERMINED BY PIPE SIZE, AS NOTED.	
⑬		PLATE STRAINER, IF SUPPLIED WITH TURBO METER (TYP.)	



Rev. Date	By	Approve
2/23/17	SMD	JB
11/03/21	SMD	AWC



TYPICAL 1.5" THRU 2" WATER SERVICE INSTALLATION

DRAWING NO.

W-2

X:\RECORD FILES\DISTRICT STANDARDS\DISTRICT DRAWINGS\WATER

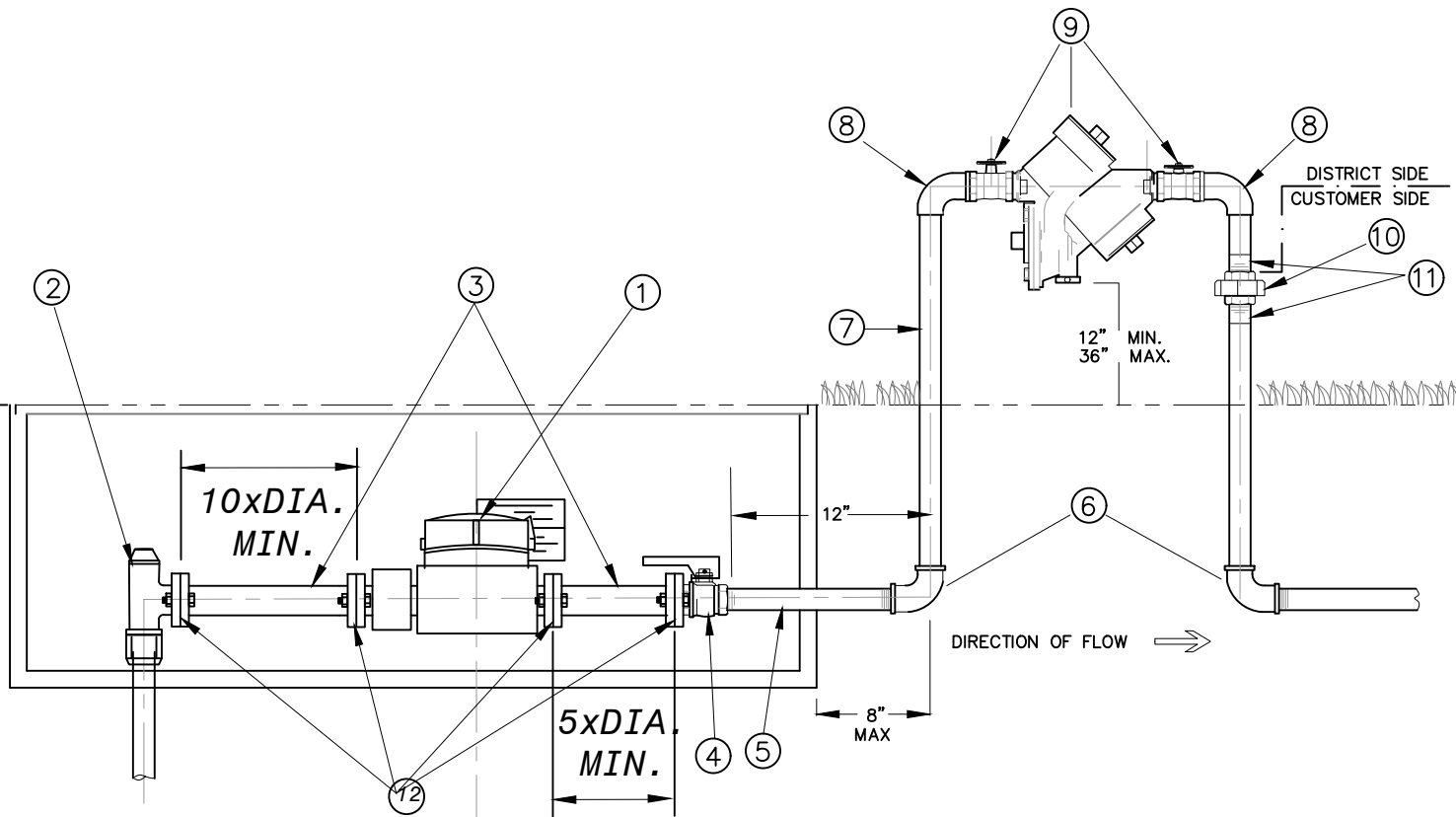

INSTALLED PER DWG NO. W-2

MATERIAL LIST

ITEM	QTY	PART TYPE	PART NO.
1	1	METER (SUPPLIED BY THE DISTRICT)	1.5" OR 2" METER, INSTALLED PER W-2
2	1	ANGLE STOP (BY SIZE OF METER)	JONES 1527 F, INSTALLED PER W-2
3	2	FLANGED BRASS SPOOL..	LENGTH DETERMINED BY PIPE SIZE, AS NOTED.
4	1	BALL VALVE, BRASS, W/ LOCKING WING	E-1913W (FLG W/ BRASS HANDLE)
5	1	COPPER OR BRASS NIPPLE (MIP X MIP)	(12" MAX. LENGTH)
6	2	90° EL	C X FIP 90
7	REQ'D	TYPE K HARD COPPER PIPE	TYPE K
8	2	90° EL	C X MIP 90
9	1	R.P. DEVICE WITH BALL VALVES	WILKINS 975XL
10	1	UNION, THREADED BRASS	FIP X FIP, BY METER SIZE.
11	2	ADAPTER	C X MIP ADAPTER
12	2	USE FPUD APPROVED GASKET WASHERS.	FLANGE GASKET (METERSEAL-O RUBBER, W/RAISED O-RING)

NOTE:

CUSTOMER IS RESPONSIBLE TO PROTECT PRIVATE FACILITIES AND TO SUPPLY PRESSURE REDUCING VALVE WHEN PRESSURE IS HIGH. REFER TO THE UNIFORM PLUMBING CODE AND PRIVATE ENGINEER REGARDING INSTALLATION OF A PRESSURE REGULATOR AFTER METER. MAXIMUM PRESSURE ALLOWED FOR R.P. DEVICES IS 175 PSI. CONTACT ENGINEERING TO DISCUSS IF STATIC PRESSURE AT METER IS OVER 175 PSI.

11/3/21 - WAS PART OF W-1A, CHANGED TO W-2A



REV. DATE	BY	APPV'D
2/23/17	SMD	JB
11/03/21	SMD	AWC



1.5" TO 2" METER WITH REDUCED PRESSURE BACKFLOW DEVICE

DRAWING NO.

W-2A

X:\RECORD FILES\DISTRICT STANDARDS\DISTRICT DRAWINGS\WATER

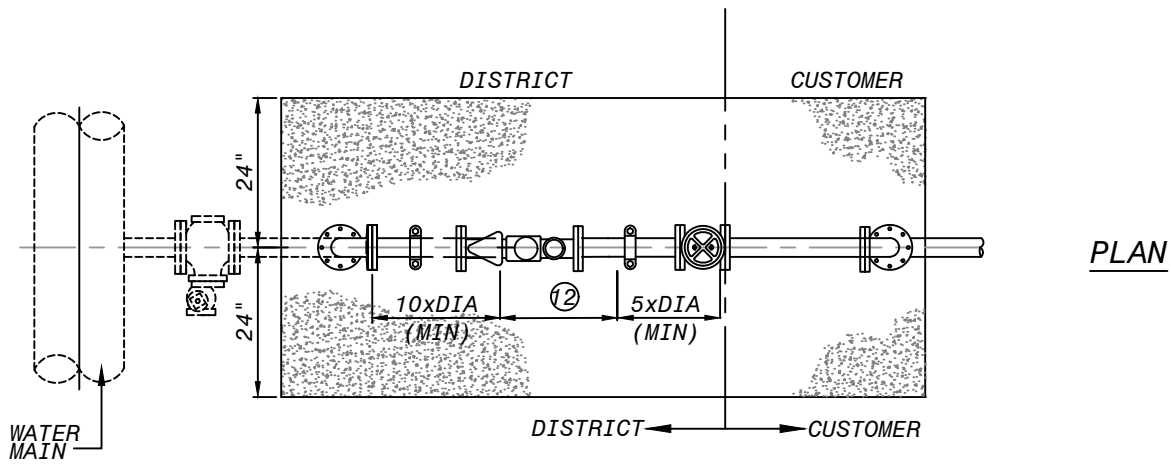

PLAN

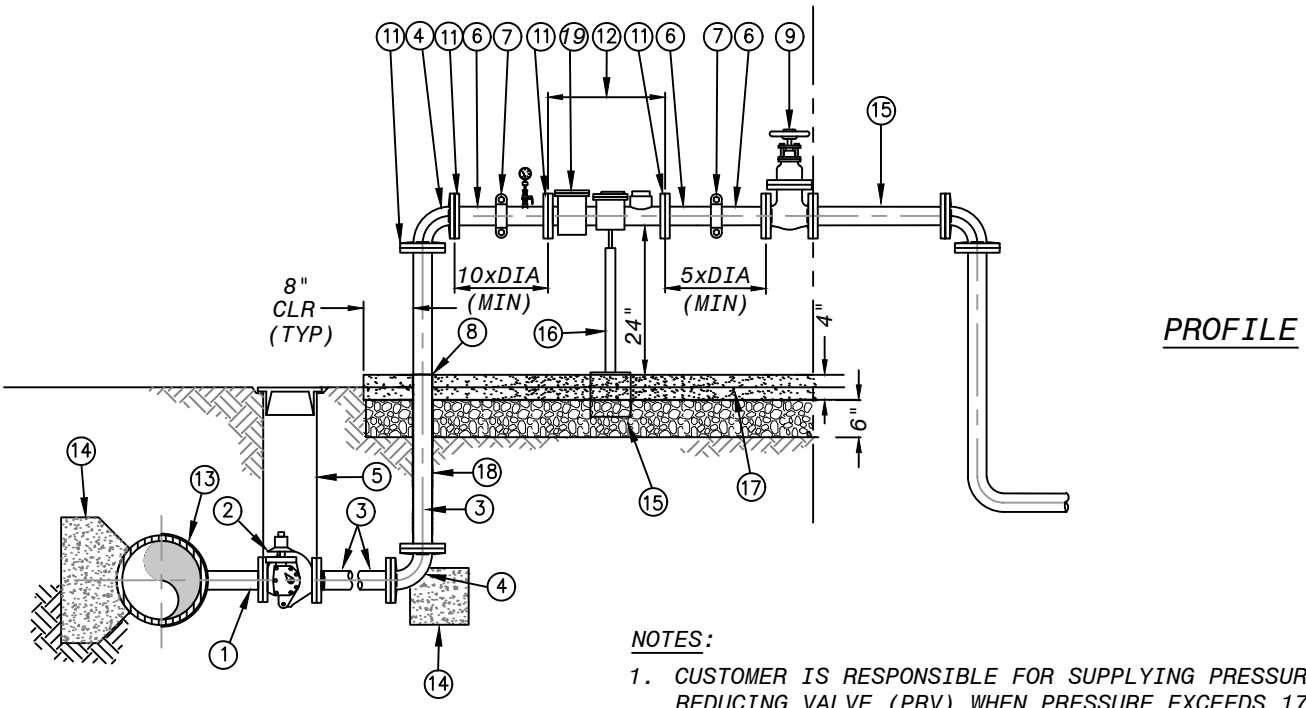

PROFILE

NOTES:

- CUSTOMER IS RESPONSIBLE FOR SUPPLYING PRESSURE REDUCING VALVE (PRV) WHEN PRESSURE EXCEEDS 175 PSI. REFER TO THE UNIFORM BUILDING CODE AND A PRIVATE ENGINEER REGARDING INSTALLATION OF A PRV AFTER THE METER.

MATERIAL LIST

- | | |
|--|---|
| <ul style="list-style-type: none"> ① 3" FLANGED OUTLET PER AWWA AND DISTRICT STANDARDS ② 3" FLANGED GATE VALVE, (OR FLANGED PLUG VALVE, WHERE PRESSURE IS GREATER THAN 250 PSI ③ 3" DI PIPE T.2E. ④ 3"x 90° DI PIPE ELBOW, FLANGED. ⑤ VALVE BOX INSTALLATION PER DISTRICT STD. DWG NO. W-19 ⑥ 3" FLANGE x GROVE END SPOOL. ⑦ 3" COUPLING, 150-LB, GALVANIZED. ⑧ WRAP WITH FOAM TAPE FOR CONCRETE PENETRATION ⑨ 3" GATE VALVE, FLANGED, ⑩ 3" COMPANION FLANGE, FLANGED, 150-LB ⑪ WATER METER SUPPLIED BY DISTRICT ⑫ HALF WRAP WELD SADDLE | <ul style="list-style-type: none"> ⑬ THRUST BLOCK, FPUD SEC 03300 ⑭ OPTIONAL SPOOL ⑮ ADJUSTABLE STAINLESS STEEL PIPE SUPPORT FOR 3" PIPING. ⑯ STEEL REBAR 12" O.C. EACH WAY GRADE 60, #4 AT MID-DEPTH. ⑰ WRAP PER DISTRICT STANDARD WITH 8 MIL POLYETHYLENE ⑱ METER STRAINER MAY BE INCLUDED WITH METER. IF STRAINER IS USED BEFORE UPSTREAM SPOOL, LENGTH OF SPOOL CAN BE REDUCED FROM 10XDIA. TO 5XDIA. SEE DISTRICT ENG. FOR MORE INFORMATION. |
|--|---|

11/3/21 - CHANGED TO W-3, WAS W-2

	REV. DATE	BY	APPROVED		<h2 style="margin: 0;">3" - 6" WATER SERVICE</h2>	DRAWING NO.
	9/21/16	SMD	JRB			W-3
	11/03/21	SMD	AWC			

X:\RECORD FILES\DISTRICT STANDARDS\DISTRICT DRAWINGS\WATER

PLAN

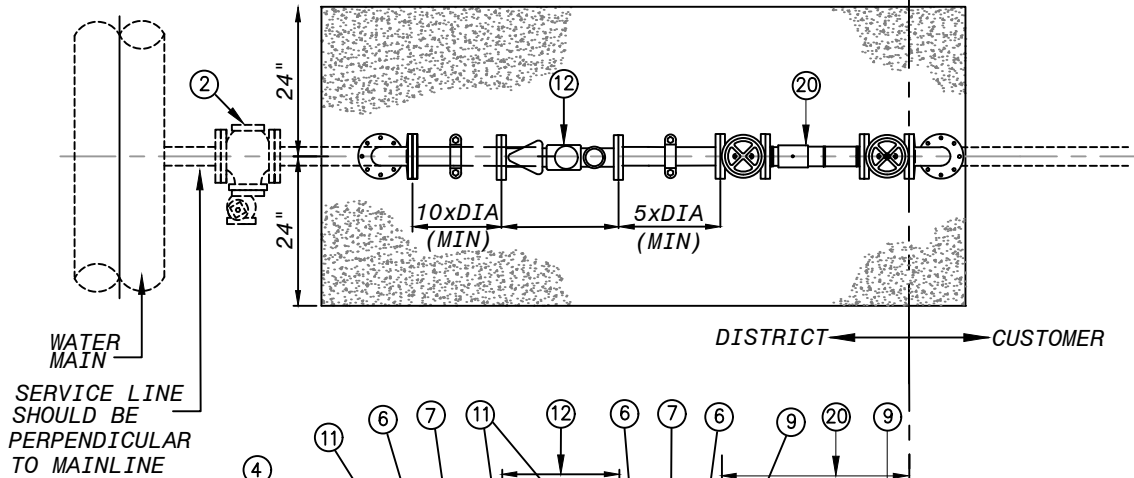

PROFILE

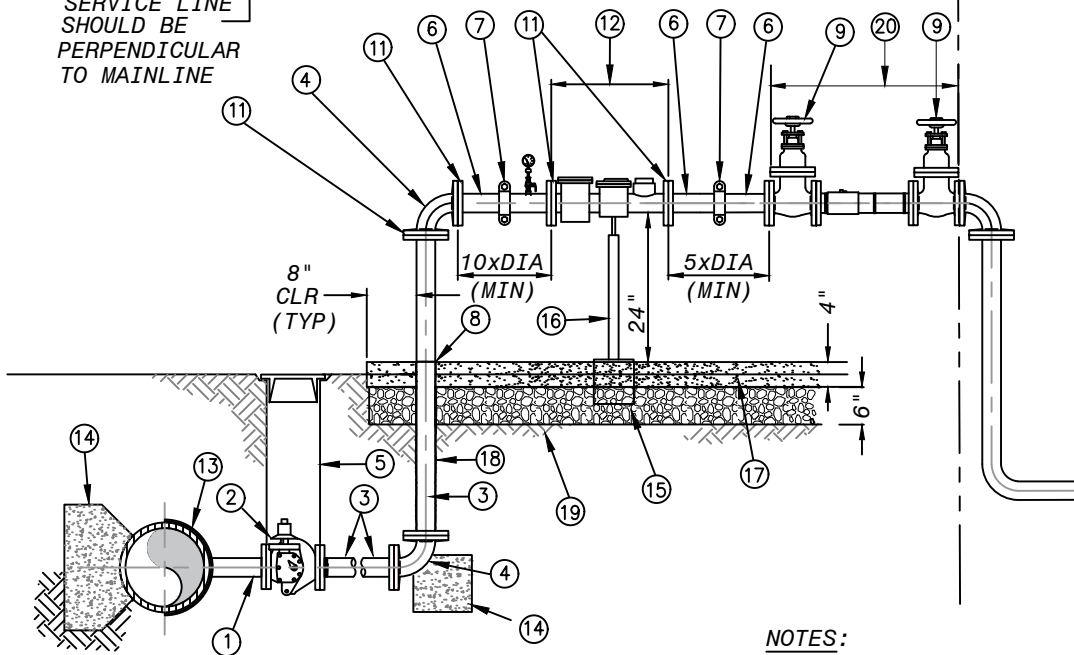

MATERIAL LIST PER METER SIZE X" (MINIMUM)

ITEM	QTY	MATERIAL DESCRIPTION	(PART NO.)
①		X" FLANGED OUTLET PER AWWA AND DISTRICT STANDARDS	
②		X" FLANGED GATE VALVE, (OR FLANGED PLUG VALVE, WHERE PRESSURE IS GREATER THAN 250 PSI)	
③		X" DUCTILE IRON PIPE (DIP) T.2E.	
④		X" 90° DI PIPE ELBOW, FLANGED.	
⑤		VALVE WELL INSTALLATION PER DISTRICT STD. DWG NO.W-19	
⑥		X" FLANGE x GROVE END SPOOL.	
⑦		X" COUPLING, 150-LB, GALVANIZED.	
⑧		WRAP WITH FOAM TAPE FOR CONCRETE PENETRATION	
⑨		X" GATE VALVE, FLANGED	
⑩		X" COMPANION FLANGE, FLANGED, 150-LB	
⑪		WATER METER AND RADIO RTU SUPPLIED BY DISTRICT (SEE NOTE 3)	
⑫		HALF WRAP WELD SADDLE	
⑬		THRUST BLOCK, FPUD SEC 03300	
⑭		DELETED	
⑮		ADJUSTABLE STAINLESS STEEL PIPE SUPPORT FOR X" PIPING	
⑯		4" CONCRETE SLAB, #4 STEEL REBAR 12" O.C. EACH WAY GRADE 60, AT MID-DEPTH	
⑰		WRAP PER DISTRICT STANDARD WITH 8 MIL POLYETHYLENE	
⑱		BACKFILL WITH AGGREGATE BASE, (95% REL. COMPACTION)	
⑳		REDUCED PRESSURE BACKFLOW PREVENTION DEVICE AS REQUIRED AND APPROVED BY THE DISTRICT - SHALL MATCH METER SIZE.	

NOTES:

- 1) CUSTOMER IS RESPONSIBLE FOR SUPPLYING PRESSURE REDUCING VALVE (PRV) WHEN PRESSURE EXCEEDS 175 PSI. REFER TO THE UNIFORM BUILDING CODE AND A PRIVATE ENGINEER REGARDING INSTALLATION OF A PRV AFTER THE METER AND BEFORE BACKFLOW.
- 2) INSTALLATION, MATERIALS AND VALVES SHALL BE ACCORDING TO DISTRICT SPECIFICATIONS. SEE FOR MORE INFORMATION.
- 3) METER STRAINER MAY BE INCLUDED WITH METER. IF STRAINER IS USED BEFORE UPSTREAM SPOOL, LENGTH OF SPOOL CAN BE REDUCED FROM 10XDIA. TO 5xDIA. SEE DISTRICT ENG. FOR MORE INFORMATION.
- 4) PAINTING: ABOVE GROUND PIPING SHALL BE PAINTED (FOREST) GREEN, ENAMEL. DO NOT PAINT METER.

11/3/21 - CHANGED TO W-3A, WAS W-2A



REV. DATE	BY	APP'D
5/24/17	SMD	JRB
04/08/21	SMD	AWC
11/03/21	SMD	AWC



3" - 6" WATER SERVICE WITH REDUCED PRESSURE BACKFLOW DEVICE

DRAWING NO.

W-3A

X:\RECORD FILES\DISTRICT STANDARDS\DISTRICT DRAWINGS\WATER

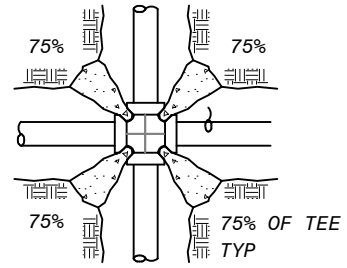
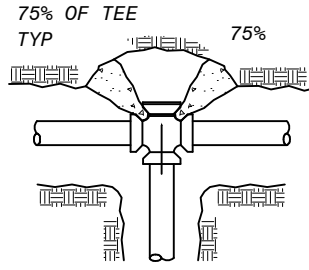
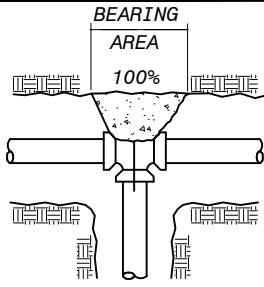

PLANS

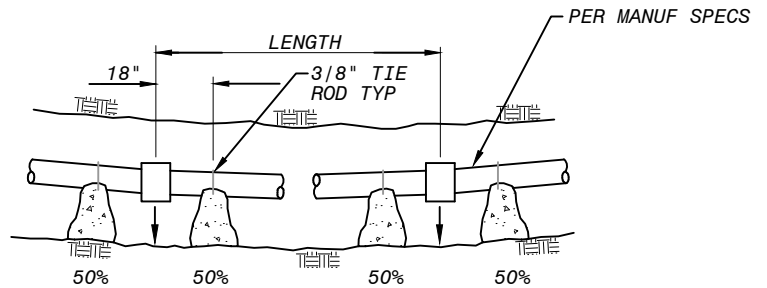
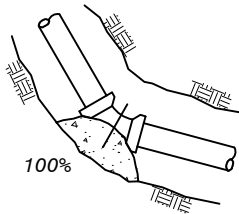
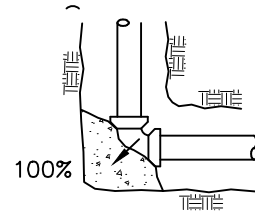
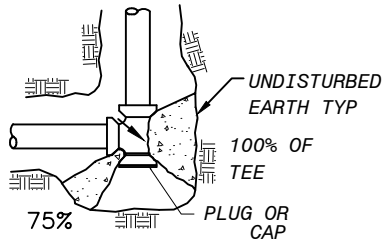
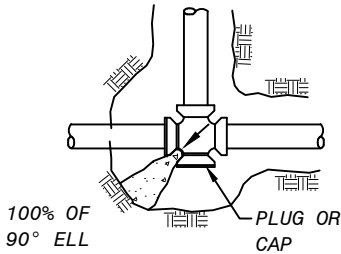

CURVE THRUST BLOCKING

WEIGHT OF CONCRETE TO RESIST 100% OF TOTAL THRUST

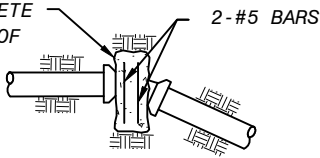

VERTICAL BEND

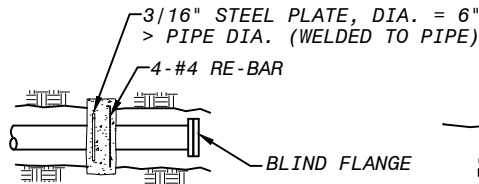

STEEL PIPE THRUST COLLAR

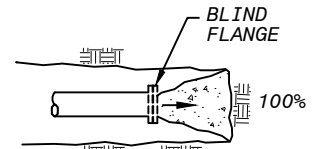

PLAN DEAD-END

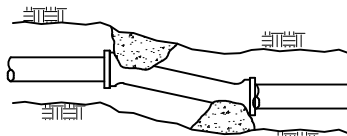

DEFLECTION

NOTES:

1. IN USING THE ABOVE TABLES, USE THE MAXIMUM INTERNAL PRESSURE ANTICIPATED (i.e. HYDROSTATIC TEST PRESSURE, POSSIBLE SURGE PRESSURE DUE TO PUMP SHUT-OFF, ETC.)
2. SEE SOILS REPORT FOR BEARING STRENGTH OF SOIL. IN THE ABSENCE OF A SOILS REPORT, AN AVERAGE SOIL (SPADABLE MEDIUM CLAY) CAN BE ASSUMED TO HAVE A BEARING STRENGTH OF 2000 P.S.F.
3. ARROWS () INDICATE THRUST DIRECTION
4. FIGURE (100%) AT THRUST BLOCK INDICATES PER CENT OF TOTAL THRUST TO BE APPLIED FOR BEARING AREA.
5. CONC. FOR THRUST BLOCKS TO BE 450-C-2000
6. CONCRETE THRUST BLOCK TO BE POURED AGAINST UNDISTURBED EARTH.

MINIMUM BEARING AREAS IN SQUARE FEET PER 100 PSI OF PRESSURE					
PIPE SIZE	DEAD END OR TEE	90° ELBOW	45° ELBOW	22-1/2° ELBOW	11-1/4° ELBOW
6	3.7	5.3	2.9	1.5	0.7
8	6.4	9.1	4.9	2.5	1.3
10	9.7	13.7	7.4	3.8	1.9
12	13.7	19.4	10.5	5.3	2.7
14	18.4	26.0	14.1	7.2	3.6
16	23.8	33.6	18.2	9.3	4.7
18	24.9	42.2	22.9	11.7	5.9
20	36.6	51.8	28.0	14.3	7.2
24	52.3	73.9	40.0	20.4	10.2
30	80.4	113.7	61.6	31.4	15.8



REV. DATE	BY	APPROVED
5/24/17	SMD	JRB



CONCRETE THRUST BLOCKS

DRAWING NO.
W-4

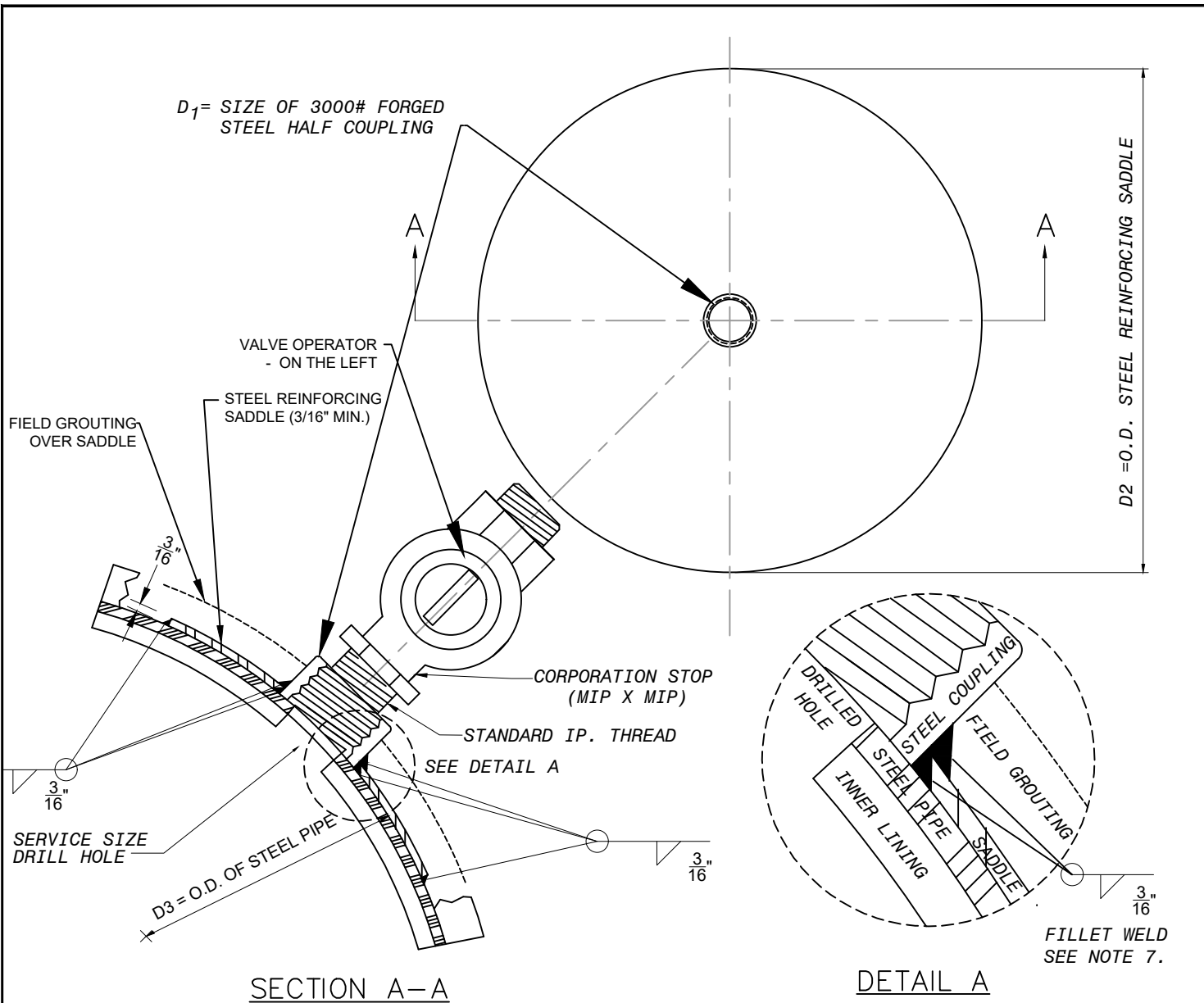

SECTION A-A

DETAIL A

NOTES:

1. USE DOUBLE-PASS WELDS FOR FABRICATION & FIELD WELDS.
2. SADDLE CURVATURE TO BE FORMED TO MEET PIPE DIAMETER D3, AS INDICATED.
3. WHEN INSTALLED. OUTLET TO BE COATED WITH SAME COATING AS PIPE.
4. SERVICE LATERALS TO BE INSTALLED AT 45° ANGLE ABOVE SPRINGLINE OF PIPE.
5. SERVICE CONNECTION CAN BE MADE WITH LINE IN SERVICE (HOT-TAPPED).
6. BUSHINGS ARE NOT ALLOWED.
7. HALF COUPLING IS PLACED ON PIPE AND FILLET WELDED PRIOR TO WELDING SADDLE AROUND COUPLING.
8. IF PIPING IS NOT HOT-TAPPED, GROUT INSIDE OF FITTING. REINFORCING SADDLE IS NOT REQUIRED.
9. IF PIPE HAS MFR WELDED COUPLINGS, SADDLES ARE NOT REQUIRED.

SADDLE DIMENSIONS		
SERVICE SIZE	D ₁	D ₂
3/4" / 1"	1"	5"
1-1/2" / 2"	1-1/2" / 2"	7"

	REV. DATE	BY	APPROVED
	2/23/17	SMD	JB
	8/28/19	SMD	AWC
	8/10/22	SMD	AWC



SERVICE OUTLET SADDLE

DRAWING NO.
W-5

X:\RECORD FILES\DISTRICT STANDARDS\DISTRICT DRAWINGS\WATER

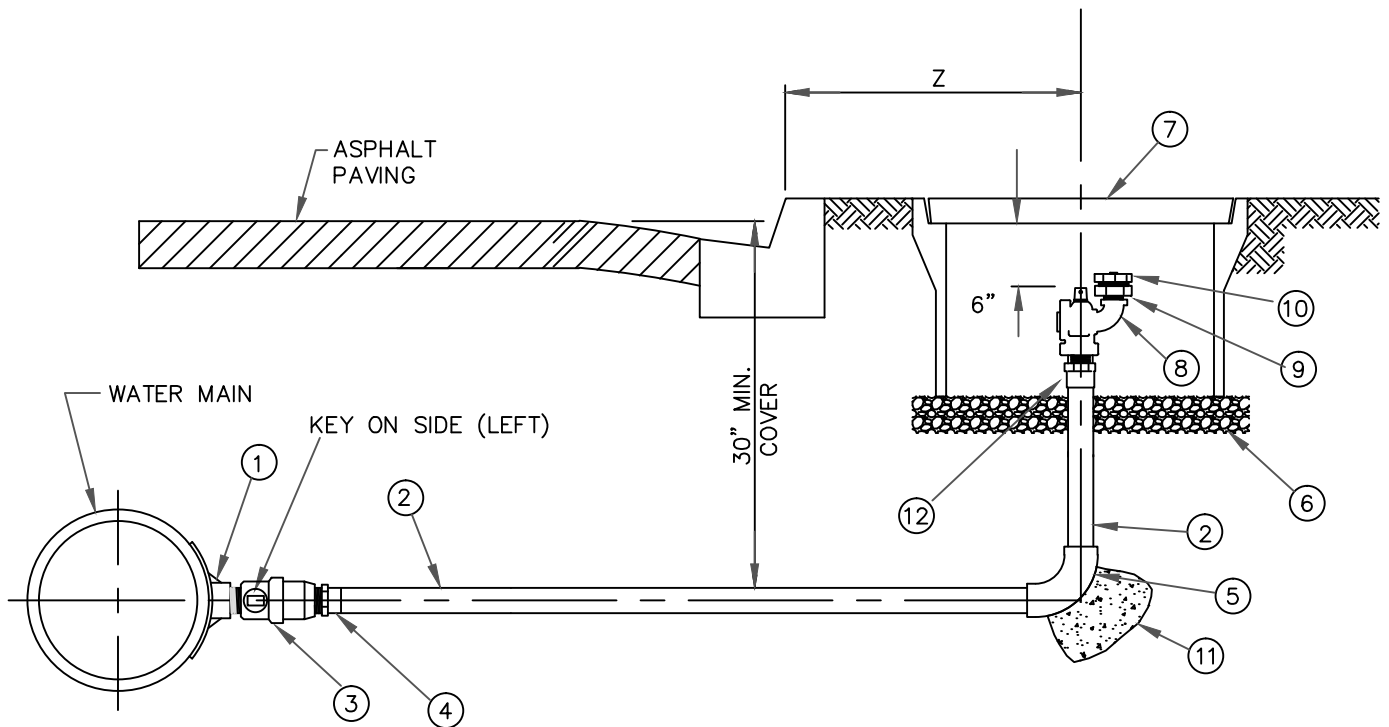

Z = 2' FROM BACK OF SIDEWALK.
2' FROM FACE OF CURB IF NO SIDEWALK EXISTS.

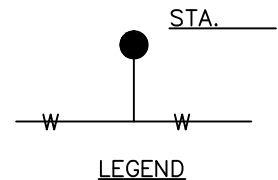

- NOTE: 1. IF BLOWOFF CANNOT BE LOCATED BEHIND OR IN THE SIDEWALK THEN IT MAY BE INSTALLED IN THE ROADWAY (IN TRAFFIC BOX). AVOID STORM GUTTER AREAS.
2. ALL JOINTS TO BE 15% SILVER SOLDERED. NO LEAD.
3. FOR PVC PIPE, USE S.S. SADDLE, AS LISTED IN THE APPROVED MATERIALS LIST.

ITEM	NO.	DESCRIPTION	REMARKS
1	1	REINFORCING SADDLE, W/ 3000# FORGED STEEL COUPLING	STEEL, WELDED, HOT TAP.
2	1	2" COPPER TUBING W/ PIPE SLEEVE	BRASS OR COPPER (TYPE K)
3	1	2 INCH BALL CORP VALVE, MIP X MIP	BRASS
4	1	PIPE (SWEAT) TO THREADED FIP ADAPTER	PER STD. DWG W-4
5		2 INCH 90° SOLDERED ELBOW	BRASS OR COPPER
6	1	3/8" GRAVEL W/ 1/4" GALVANIZED METAL MESH BOTTOM	4" TO 6" DEEP
7	1	POLYMER METER BOX WITH LID, 20" X 26" X 12", TRAFFIC BOX IF IN ST.	1220-12, 1220-4 T-COVER, NOT "METER"
8	1	2" NL BLOW-OFF BALL VALVE, FIP x MIP	BRASS, McDONALD 76109BCA F 2
9	1	BRASS 2" FIP THREAD X 2 1/2" MALE NST (HOSE THREAD) ADAPTER	BRASS (FIP X MNST)
10	1	2 1/2" NST HOSE CAP (FIRE HYDRANT THREAD)	BRASS
11	1	THRUST BLOCK	PER STD. DWG W-4
12	1	2-INCH PIPE (SWEAT) TO THREADED MIP ADAPTER	BRASS / COPPER

X:\RECORD FILES\DISTRICT STANDARDS\DISTRICT DRAWINGS\WATER

	REV. DATE	BY	APPR'D		2" BLOW-OFF ASSEMBLY (for 6" to 8" pipe)	DRAWING NO.
	5/24/17	SMD	JRB			W-6
	3/13/18	SMD	JRB			
	9/25/19	SMD	AC			

NOTES:

- 1) WRAP UNDERGROUND FACILITIES PER DISTRICT STANDARDS WITH 8 MIL POLYETHYLENE.
- 2) COAT THREADS WITH ANTI-SIEZE.
- 3) SS BOLTS AND NUTS UNDERGROUND.
- 4) INSTALL BOLLARD GUARD POSTS PER W-12

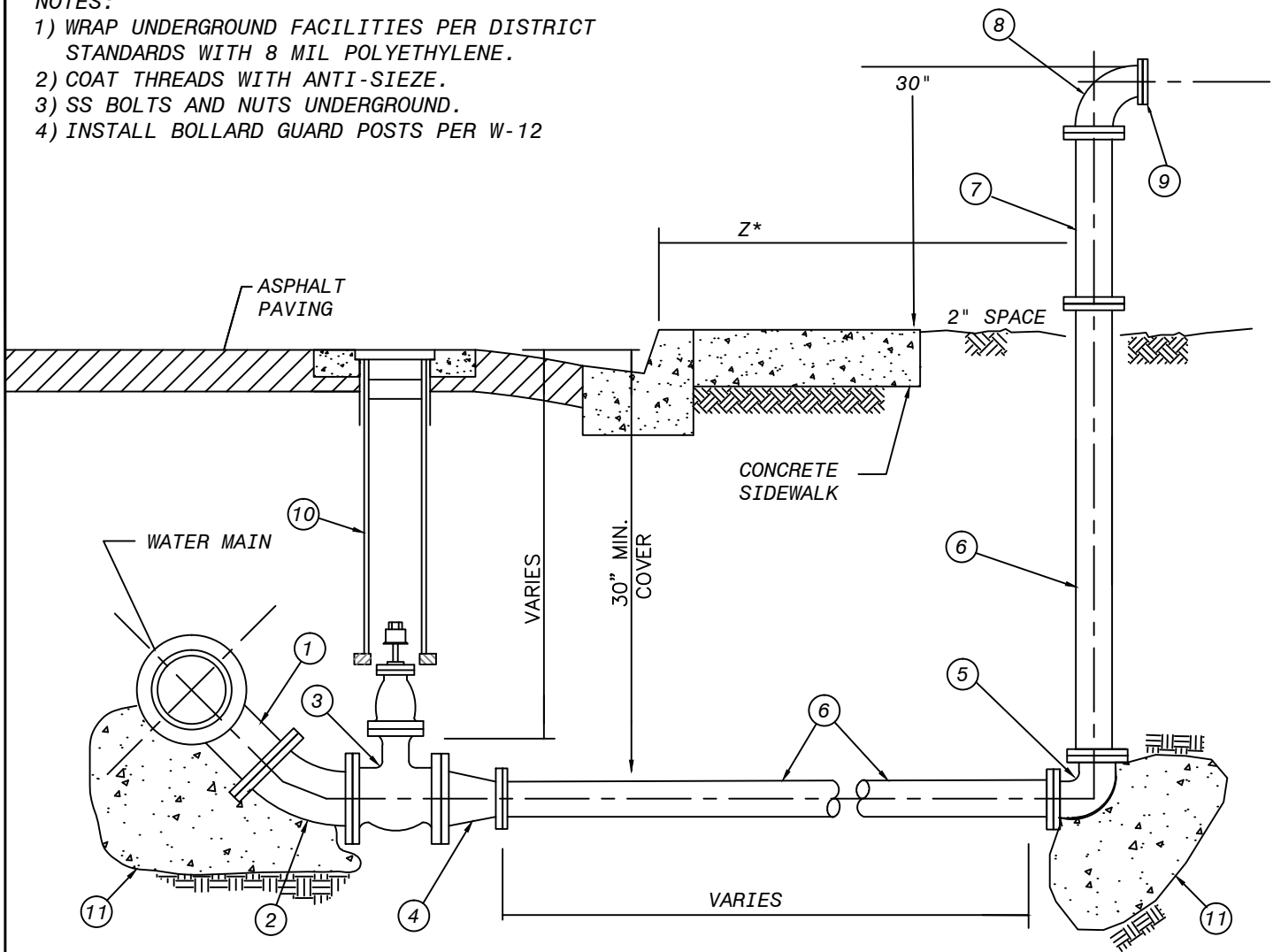

*Z- 2'-6" FROM BACK OF SIDEWALK.
2'-6" FROM FACE OF CURB IF NO SIDEWALK EXISTS.

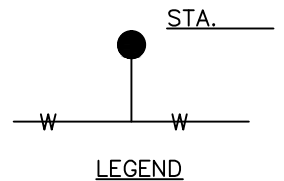

ITEM	NO.	DESCRIPTION	REMARKS
1	1	6" FLANGED OUTLET - WELDED, WITH REINFORCING SADDLE	STEEL CML&C
2	1	6" 45° FLG X FLG ELL	STEEL CML&C (DIP ACCEPTABLE)
3	1	6" GATE VALVE, FLG.X FLG., 2" NUT	PER DISTRICT STANDARD 15100
4	-	6" X 4" REDUCER. FLG X FLG, STEEL	
5	1	4" FLG. 90° BEND	STEEL CML&C (DIP ACCEPTABLE)
6	1	4" CML&C STEEL PIPE - WELDED	
7	1	4" X 24" SPOOL - BREAKAWAY IF AVAILABLE	DIP FLG X FLG
8	1	4" X 4" 90 DEGREE ELL	DIP FLG X FLG
9	1	4" BLIND FLANGE	STEEL
10	-	VALVE BOX INSTALLATION PER DISTRICT STD. DWG# W-19	
11	-	THRUST BLOCK	PER FPU D STD., DET W-4

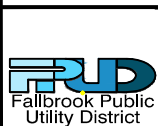

REV. DATE	BY	APPROVED
5/24/17	SMD	JRB
9/23/19	SMD	AWC



4" BLOW-OFF ASSEMBLY
(FOR PRESSURE LESS THAN 250 PSI)
(FOR 10" to 16" PIPE)

DRAWING NO.
W-7

NOTES:

- 1) WRAP UNDERGROUND FACILITIES PER DISTRICT STANDARDS WITH 8 MIL POLYETHYLENE.
- 2) COAT THREADS WITH ANTI-SIEZE.
- 3) SS BOLTS AND NUTS UNDERGROUND.
- 4) INSTALL BOLLARD GUARD POSTS PER W-12

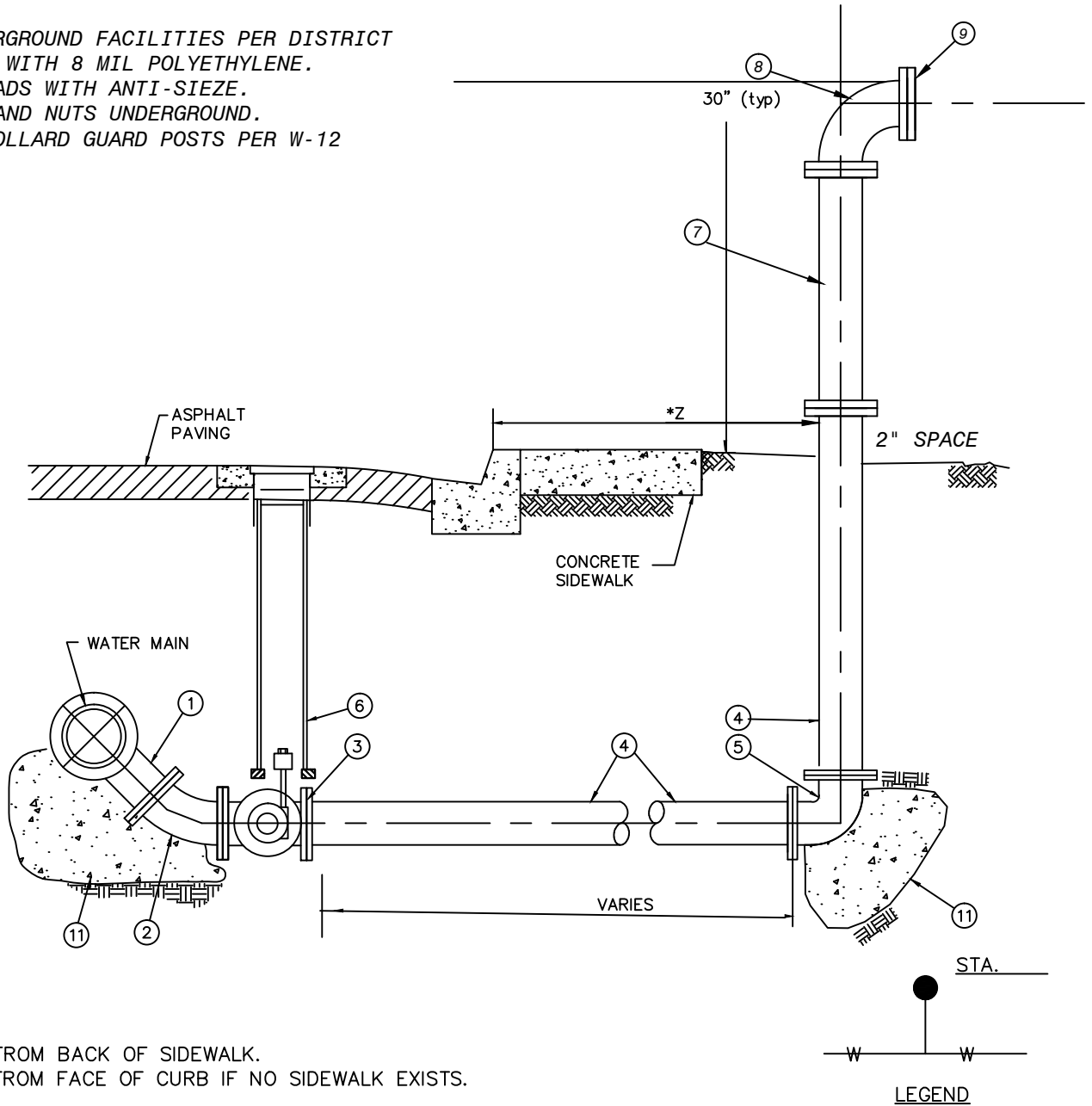

*Z 2' FROM BACK OF SIDEWALK.
2' FROM FACE OF CURB IF NO SIDEWALK EXISTS.

ITEM	NO.	DESCRIPTION	REMARKS
1	1	4" FLANGED OUTLET	STEEL, CMLC, PIPE
2	1	4" FL X FL 45° ELL	DIP
3	1	4" PLUG VALVE, FLG X FLG. WITH WEATHERPROOF GEARS	
4	-	4" DIP, FL X FL, USE MJ ADAPTERS WITH RESTRAINTS	LENGTH AS REQ'D
5	1	4" 90°, FLG.	DIP
6	1	VALVE BOX INSTALLATION PER STD. DWG W-19	
7	1	4" x 24" DIP, SPOOL, FL X FL	OR LENGTH AS REQ'D
8	1	4" 90°, FLG.	DIP
9	1	4" BLIND FLANGE	STEEL
10			
11	2	THRUST BLOCK	PER FPUD STD. DETAIL DWG W-4

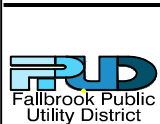

REV. DATE	BY	APPR
5/24/17	SMD	JRB
9/23/19	SMD	AWC



4" BLOW-OFF ASSEMBLY
(FOR PRESSURE 250 PSI & GREATER)
(for 10" to 16" pipe)

DRAWING NO.

W-8

NOTES:

- 1) FIRE HYDRANTS INSTALLED AT STREETS OR ROADS WITHOUT CURBS, OR WITH ROLLED CURBS, SHALL BE PROTECTED WITH GUARD POSTS (2). PER FPUD STD DETAIL W-13
- 2) IF GUARD POSTS ARE USED - ENSURE HYDRANT OUTLETS AREN'T BLOCKED BY POSTS, PER FIRE DEPT.
- 3) WRAP UNDERGROUND FACILITIES PER DISTRICT STANDARDS WITH 8 MIL POLYETHYLENE.
- 4) IN EXPOSED TRAFFIC LOCATIONS, INSTALL BREAK-OFF CHECK VALVE, PER DISTRICT ENGINEER

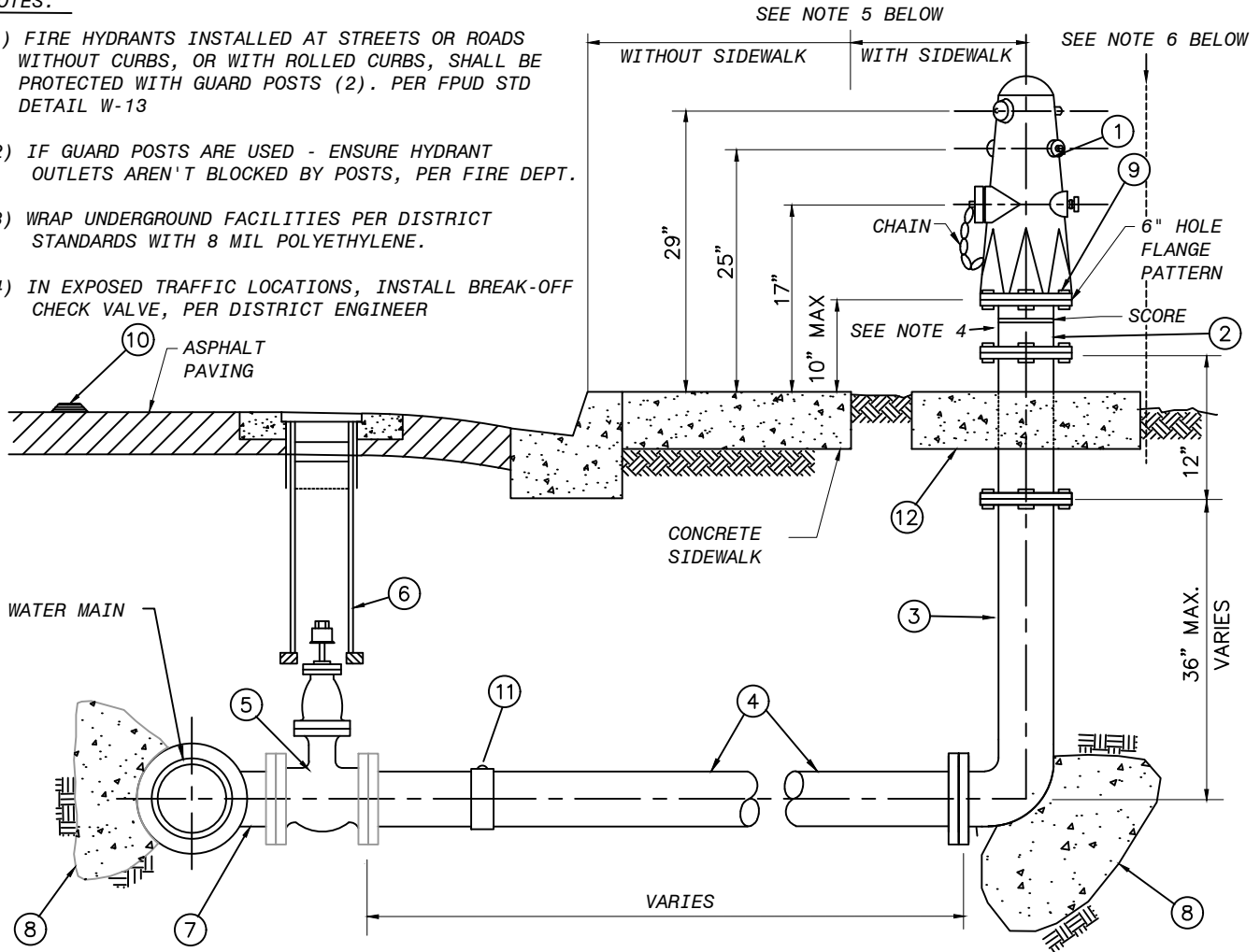

NOTES (CONT'D):

- 5) IF SIDEWALK IS PRESENT, 2'6" FROM BACK OF SIDEWALK, IF NO SIDEWALK EXISTS, 2'6" FROM THE FACE OF CURB
- 6) RIGHT OF WAY/EASEMENT BOUNDARY (UNLESS ALTERNATE LOCATION APPROVED BY THE DISTRICT ENGINEER)

DESCRIPTION		BARRELS OUTLETS	
RESIDENTIAL FIRE HYDRANT (MODEL J-3700)		2 PORT: 4" & 2-1/2"	
COMMERCIAL FIRE HYDRANT (MODEL J-3765)		3 PORTS: 4", 2-1/2" & 2-1/2"	

ITEM	NO.	DESCRIPTION	REMARKS
1	1	6" FIRE HYDRANT	6 BOLTS, ALL BRONZE, SAFETY YELLOW
2	1	BREAK-OFF RISER, 6" STEEL OR DUCTILE IRON	SCORED (NOT MOLDED)
3	1	DUCTILE IRON BURY ELL	
4	-	6" CML & C	
5	1	6" GATE VALVE FL OR PO	PER STANDARD SPECIFICATION
6	1	VALVE BOX INSTALLATION PER DISTRICT STD. DWG# W-19	SEE STANDARD SPECIFICATION
7	1	6" FLANGED OUTLET	PER STANDARD SPECIFICATION
8	1	THRUST BLOCK	PER FPUD STD. 03300
9	6	BREAK OFF BOLTS, THREADS UP FILL W/SILICON	PER STANDARD SPECIFICATIONS
10	1	REFLECTIVE PAVEMENT MARKER (BLUE)	PER FIRE DISTRICT REQUIREMENTS
11	-	6" BUTTSTRAP (IF NEEDED)	
12	1	4' x 4' CONCRETE PAD, 6" THICK, 520-C-2500	



Rev. Date	By	Approve
5/24/17	SMD	JB
5/9/24	MDC	AWC



6" FIRE HYDRANT ASSEMBLY
(FOR PRESSURE LESS THAN 250 PSI)

DRAWING NO.
W-9

NOTES:

- 1) FIRE HYDRANTS INSTALLED AT STREETS OR ROADS WITHOUT CURBS, OR WITH ROLLED CURBS, SHALL BE PROTECTED WITH GUARD POSTS (2). PER FPUD STD DETAIL W-13
- 2) IF GUARD POSTS ARE USED - ENSURE HYDRANT OUTLETS ARE NOT BLOCKED BY POSTS, PER FIRE DEPT.
- 3) WRAP UNDERGROUND FACILITIES PER DISTRICT STANDARDS WITH 8 MIL POLYETHYLENE.
- 4) FOR PRESSURE BELOW 250 PSI, GATE VALVE MAY BE USED.

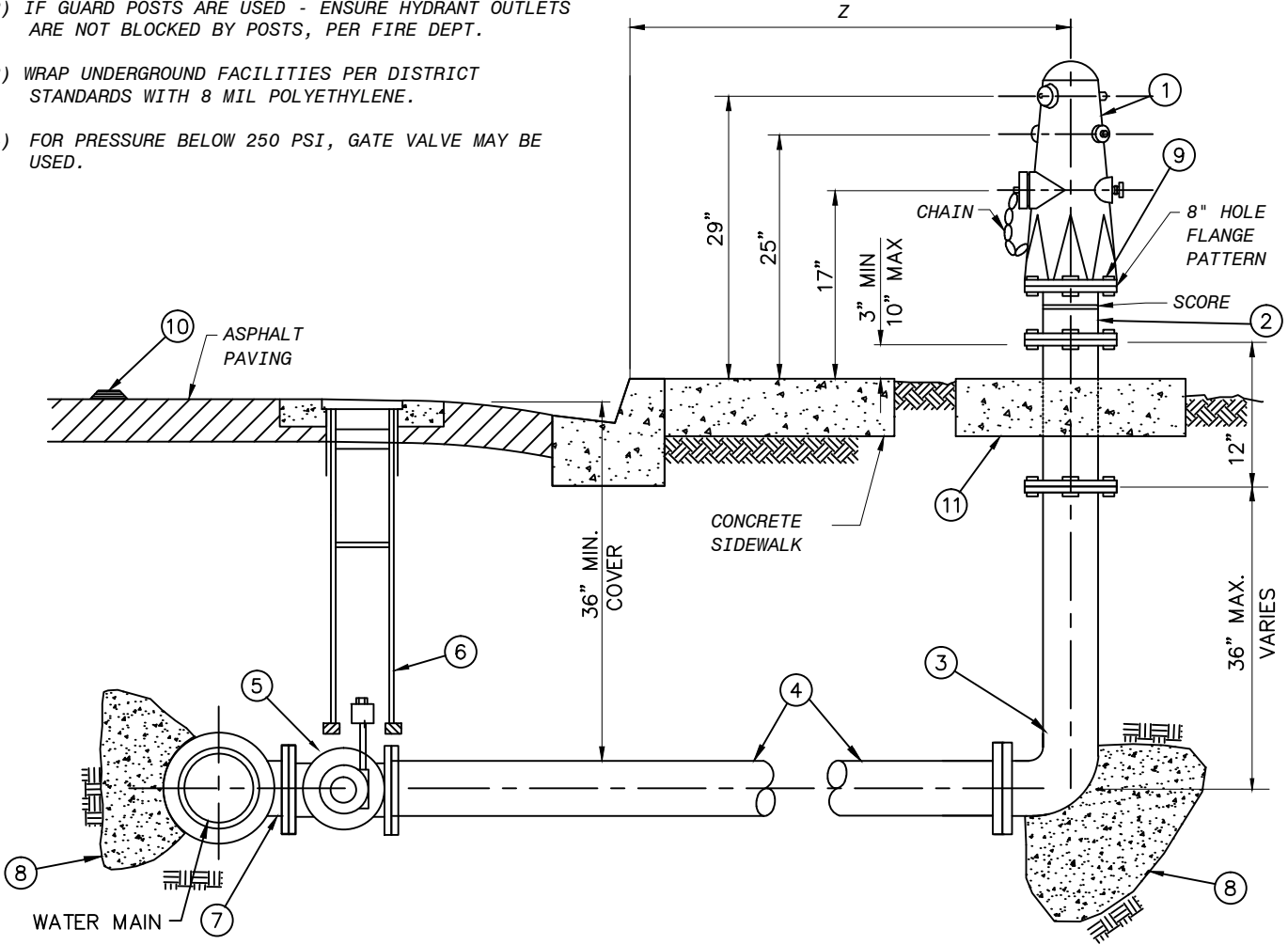

Z = 2' FROM BACK OF SIDEWALK.
 2' FROM FACE OF CURB IF NO SIDEWALK EXISTS.

ITEM	NO.	DESCRIPTION	REMARKS
1	1	6" FIRE HYDRANT	6 BOLTS,
2	1	6" BREAK-OFF RISER,	SCORED (NOT MOLDED)
3	1	6" BURIED ELL, FLG.	
4	-	6" STEEL PIPE	CL-300
5	1	6" PLUG VALVE, FLG.X FLG.	PER STANDARD SPECIFICATION, DEZURIK
6	1	VALVE BOX INSTALLATION PER DISTRICT STD. DWG# W-19	SEE STANDARD SPECIFICATION
7	1	6" FLANGED OUTLET	PER STANDARD SPECIFICATION
8	1	THRUST BLOCK	PER FPUD STD. DETAIL W-4
9	6	BOLTS BREAK OFF BELOW 300 psi.	PER STANDARD SPECIFICATIONS
10	1	REFLECTIVE PAVEMENT MARKER (BLUE) AT STREET CL	PER FIRE DISTRICT REQUIREMENTS
11	1	4' x 4' CONCRETE PAD 6" THICK, 520-C-2500	

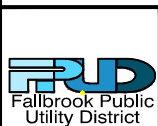

REV. DATE	BY	APPROVED
5/24/17	SMD	JRB



6" FIRE HYDRANT ASSEMBLY
 (FOR PRESSURE 250 AND GREATER)

DRAWING NO.
W-10

NOTES:

- 1) COMBINATION AAR/AV VALVES INSTALLED AT STREETS OR ROADS WITHOUT CURBS, OR WITH ROLLED CURBS, SHALL BE PROTECTED WITH (2) GUARD POSTS, PER STD DETAIL W-13, AS REQUIRED BY DISTRICT ENG. HIGH-SPEED COUNTY ROADS DO NOT PERMIT BOLLARDS.
- 2) NO DIPS OR LOW SPOTS WILL BE ALLOWED IN LATERAL PIPING INSTALLATION.
- 3) WRAP UNDERGROUND FACILITIES PER DISTRICT STANDARDS WITH 8 MIL POLYETHYLENE.
- 4) COAT SST THREADS WITH ANTI-SIEZE.
- 5) AIR VAC ASSEMBLE MUST MEET PRESSURE RATING.

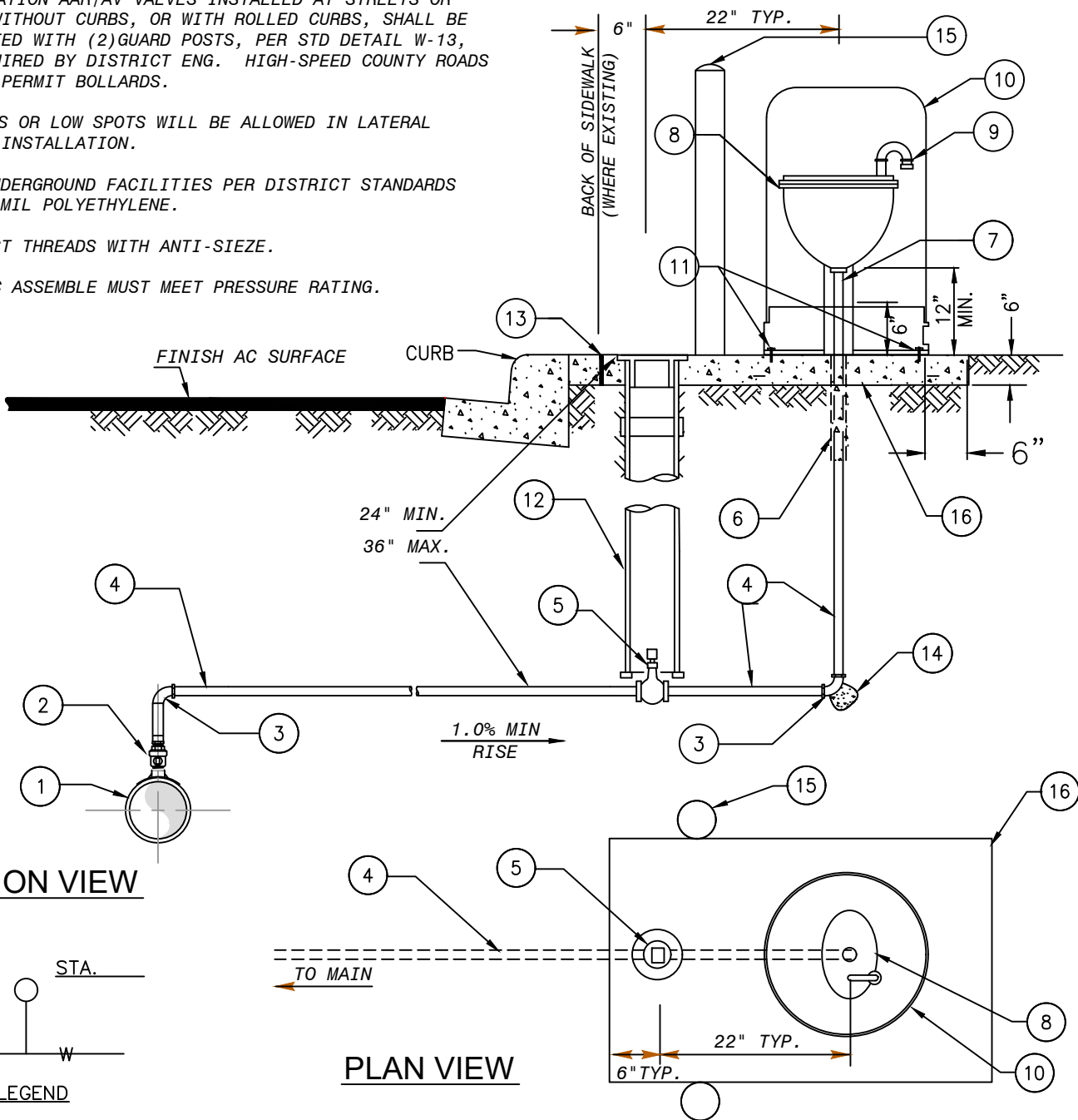

ITEM	SIZE & DESCRIPTION	ITEM	SIZE & DESCRIPTION
1	CML&C WATER MAIN - 6" TO 14" PIPE	9	CLOSE NIPPLE & RETURN BEND WITH INSECT SCREEN TURNED OUT
2	2" BRASS CORP STOP, MIP X MIP	10	HOUSING, 18" DIA.X 30", VCAS-1830, AND BASE COLOR: SANDSTONE, OR AS APPROVED BY ENG.
3	2" 90° COPPER ELL	11	316 SST, BOLTS ON ENCLOSURE BASE, RED HEAD
4	COPPER OR BRASS (W/ PIPE SLEEVE)	12	VALVE CAN INSTALLATION PER DIST.STD.DWG. W-19
5	2" PLUG VALVE, W/2" NUT HEAD, 1/4 TURN W/STOP.	13	1/2" EXPANSION JOINT
6	PVC TAPE DOUBLE WRAPPED, EXTEND 4" BELOW CONCRETE (MIN.)	14	THRUST BLOCK, PER FPU D SECTION 03300
7	BRASS CLOSE NIPPLE	15	GUARD POSTS PER W-13, AS REQUIRED BY ENG.NOTE-1
8	2" COMBINATION AUTOMATIC AIR RELEASE AND VACUUM RELIEF VALVE	16	6" THICK CONCRETE PAD

REV. DATE	BY	APPROVED
5/24/17	SMD	JRB
3/13/18	SMD	JRB
9/25/19	SMD	AWC
4/10/20	SMD	AWC
11/03/21	SMD	AWC
10/17/23	SMD	AWC

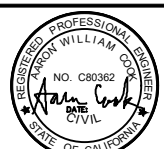

2" COMBINATION AUTOMATIC AIR RELEASE AND VACUUM RELIEF VALVE

DRAWING NO.
W-11

X:\RECORD FILES\DISTRICT STANDARDS\DISTRICT DRAWINGS\WATER

4" OR 6" DIA. SCH. 40 STEEL PIPE, PRIME & FINISH WITH ENAMEL SILVER

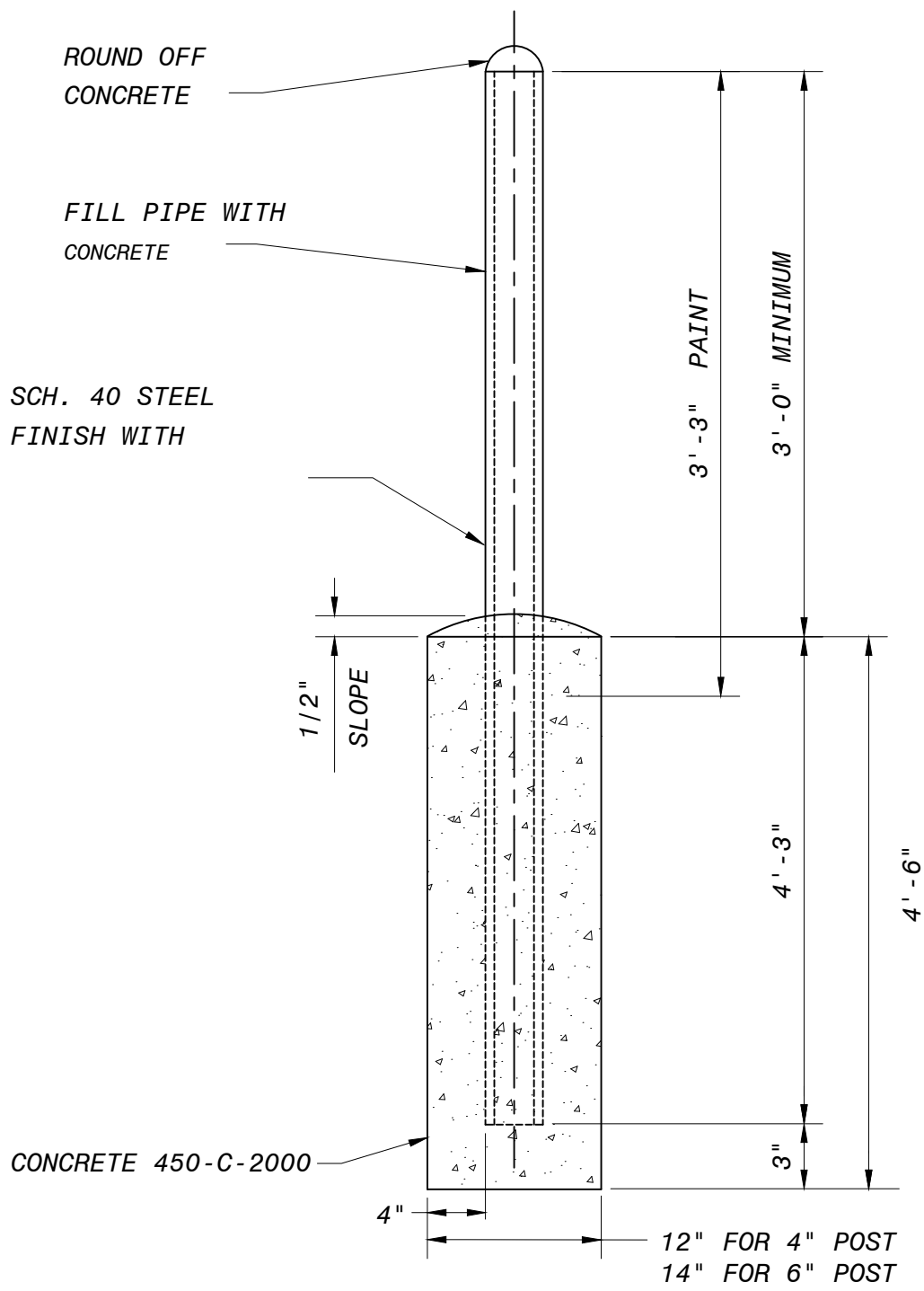

NOTES:

1. LOCATION SHALL BE AS SHOWN ON PLAN VIEW, OR AS DIRECTED IN THE FIELD BY DISTRICT ENGINEER.
2. 4" DIA. POSTS SHALL BE APPROVED BY D.E. FOR SPEED GREATER THAN 30 MPH 6" DIA. POSTS SHALL BE USED.

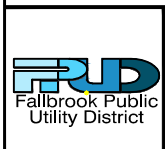

REV. DATE	BY	APPROVED
5/24/17	SMD	JRB



**GROUND POST
(BOLLARD)**

DRAWING NO.
W-13

SEPARATION STANDARDS:

1. WATER & SEWER MAINS SHALL BE INSTALLED IN SEPARATE TRENCHES.
2. PARALLEL CONSTRUCTION: THE HORIZONTAL DISTANCE BETWEEN PRESSURE WATER LINE AND SEWER OR NON-POTABLE PIPE SHALL BE AT LEAST 10 FEET.
3. PERPENDICULAR CONSTRUCTION (CROSSING): PRESSURE WATERLINES SHALL BE AT LEAST 12" ABOVE SEWER LINES OR NON-POTABLE (RECYCLED) WATERLINES, WHERE THESE LINES MUST CROSS.
4. SPECIAL PROVISIONS: ALTERNATIVE CONSTRUCTION CRITERIA WHERE THE BASIC SEPARATION STANDARDS ABOVE CANNOT BE ATTAINED ARE SHOWN BELOW.

PARALLEL CONSTRUCTION (CASE 2)

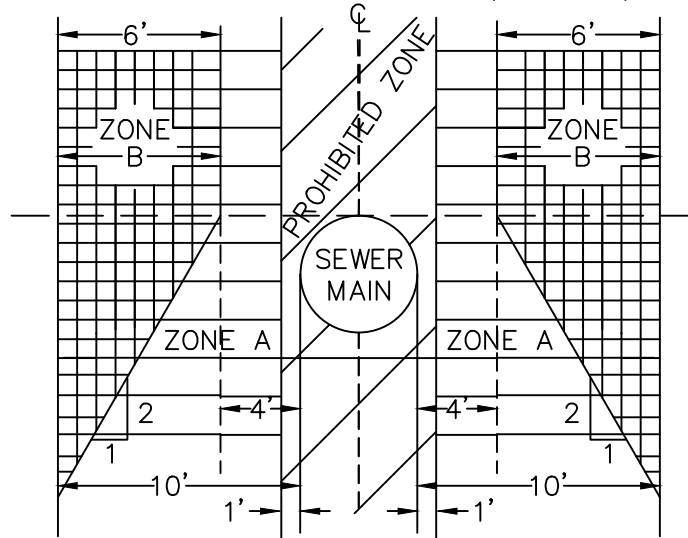

NOTES:

- A. DIMENSIONS ARE FROM OUTSIDE OF WATER MAIN TO OUTSIDE OF SEWER.
- B. SANITARY SEWERS OR WATERLINES ARE NOT PERMITTED WITHIN ANY OF THE INDICATED ZONES UNLESS CONSTRUCTED IN CONFORMANCE WITH THE SPECIAL REQUIREMENTS NOTED BELOW.

PERPENDICULAR CONSTRUCTION (CASE 2)

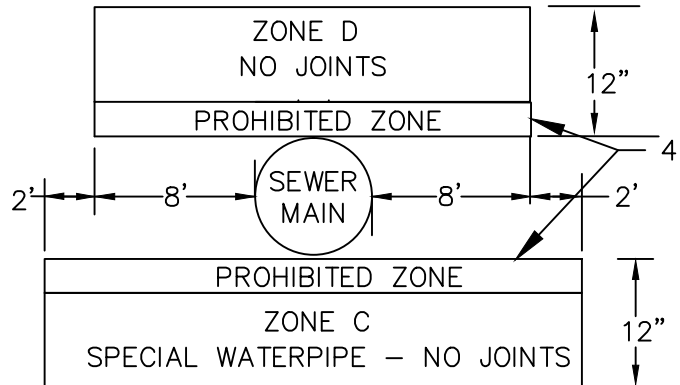

ZONE SPECIAL WATERLINE CONSTRUCTION REQUIREMENTS: (INSTALLING NEAR EXISTING SEWER MAINS = CASE 2)

- A. WATER MAINS INSTALLED RUNNING PARALLEL TO SEWER MAINS SHALL NOT BE PERMITTED WITHIN THIS ZONE WITHOUT SPECIAL WRITTEN PERMISSION FROM THE SAN DIEGO COUNTY DEPARTMENT OF ENVIRONMENTAL HEALTH.
- B. WATER MAINS INSTALLED IN THIS ZONE SHALL BE CML&C STEEL PIPE WITH WELDED JOINTS.
- C. WATER MAINS INSTALLED IN THIS ZONE, PERPENDICULAR TO AND BELOW A SEWER MAINLINE, REQUIRES THAT THE WATERLINE HAVE NO JOINTS TEN (10) FEET ON EITHER SIDE OF THE SEWER MAINLINE, AND CONSTRUCTED OF MINIMUM 1/4" WELDED CML&C STEEL PIPE.
- D. WATER MAINS INSTALLED IN THIS ZONE, ABOVE EXISTING SEWER MAINLINE, THE WATERLINE SHALL HAVE NO JOINTS WITHIN FOUR (4) FEET OF THE SEWER MAINLINE CROSSING AND BE CONSTRUCTED WITH MINIMUM 1/4" CML&C STEEL PIPE, CENTERED OVER PIPE BEING CROSSED.

	Rev.Date	By	Apprv		WATERLINE PIPE INSTALLATION & PIPELINE SEPARATION REQUIREMENTS	DRAWING NO.
	5/24/17	SMD	JRB			W-14

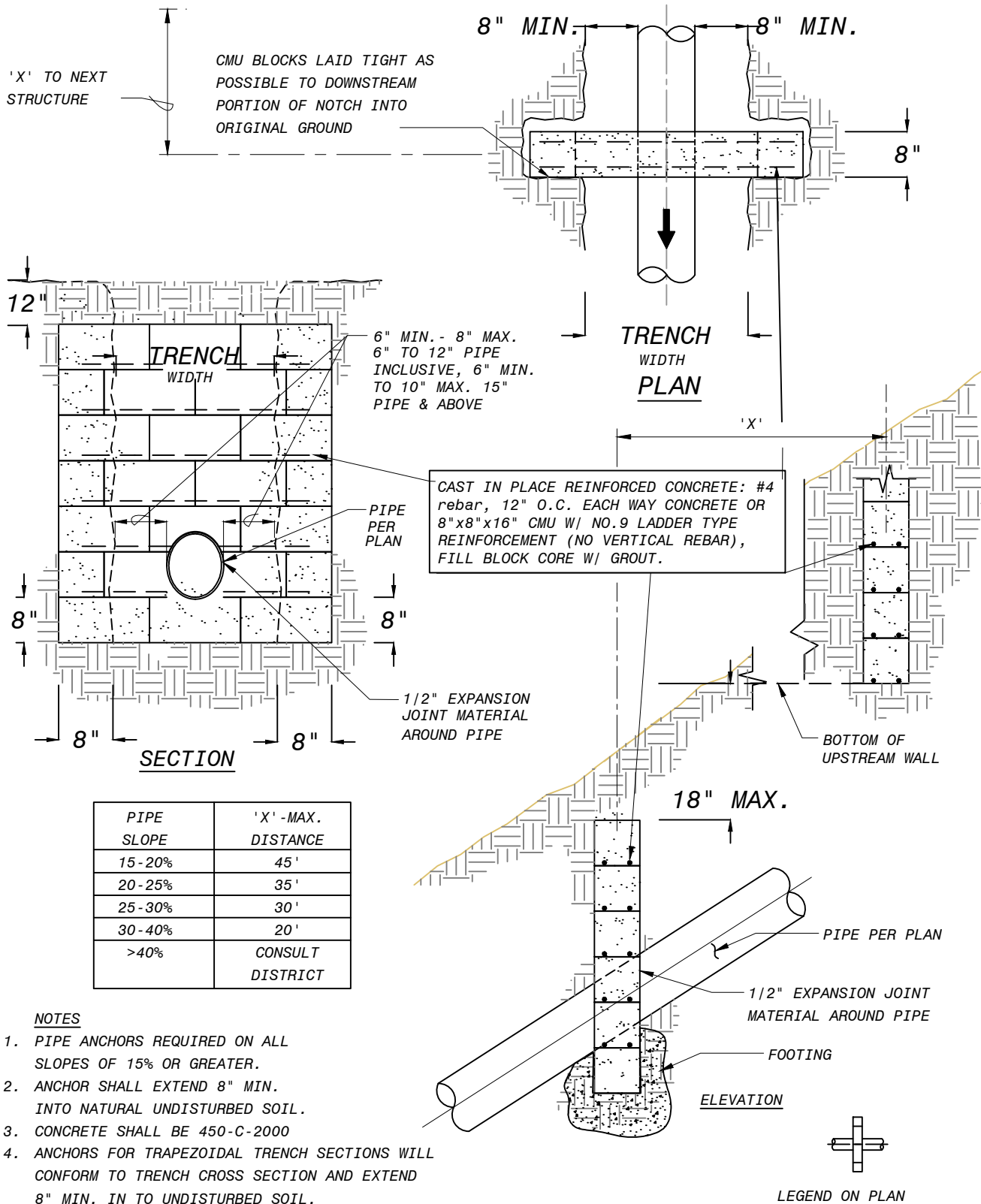

NOTES

1. PIPE ANCHORS REQUIRED ON ALL SLOPES OF 15% OR GREATER.
2. ANCHOR SHALL EXTEND 8" MIN. INTO NATURAL UNDISTURBED SOIL.
3. CONCRETE SHALL BE 450-C-2000
4. ANCHORS FOR TRAPEZOIDAL TRENCH SECTIONS WILL CONFORM TO TRENCH CROSS SECTION AND EXTEND 8" MIN. IN TO UNDISTURBED SOIL.

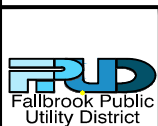

Rev. Date	By	APPRV'D
5/24/17	SMD	JRB
12/16/2020	SMD	AWC



STANDARD CUTOFF WALL

DRAWING NO.

W-15

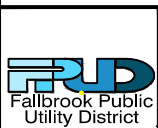
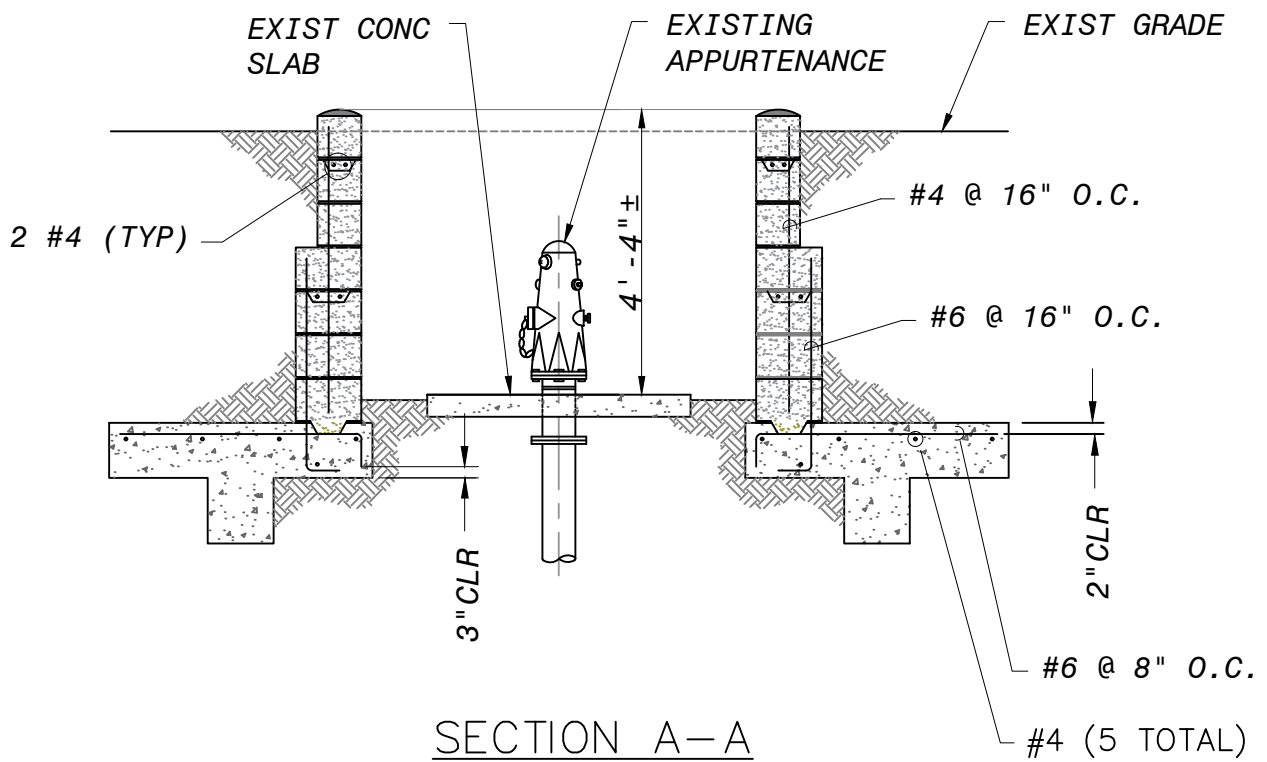
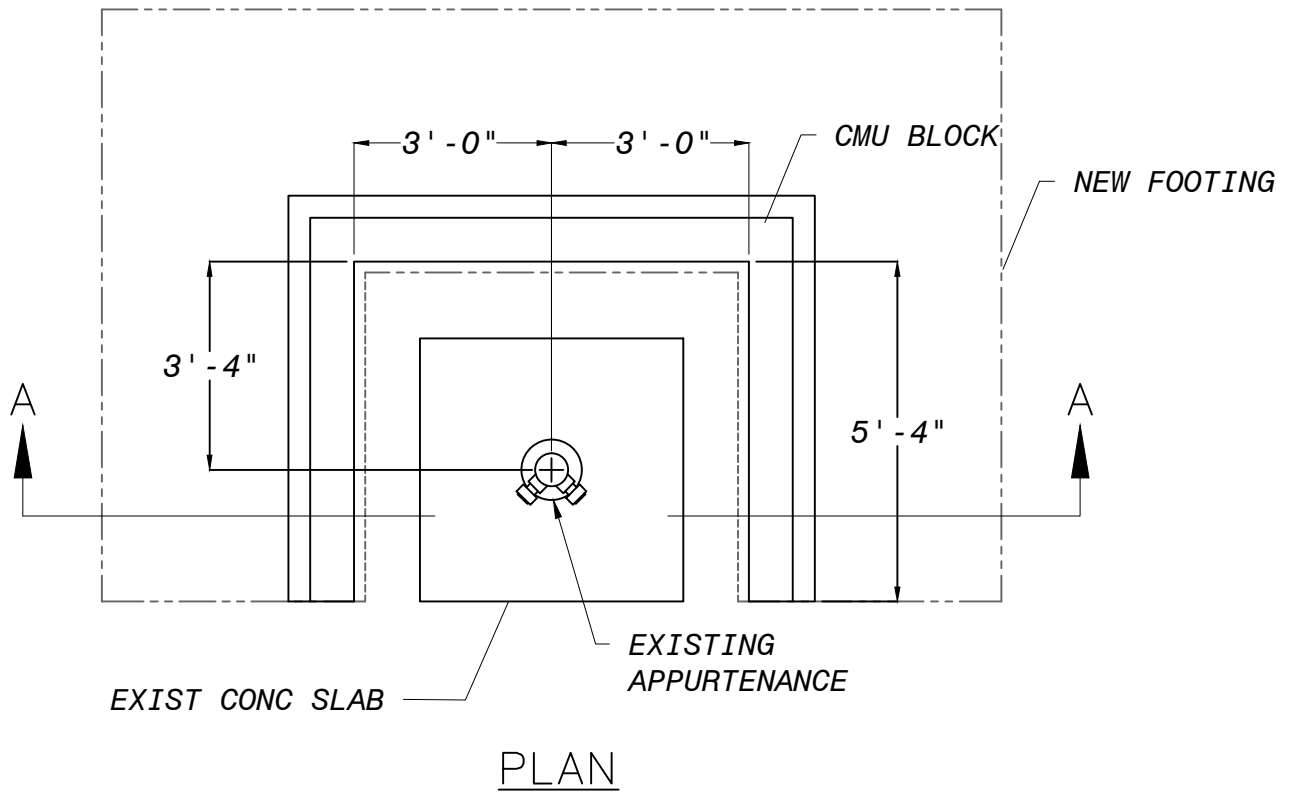

Rev. Date	By	APPRV'D
5/24/17	SMD	JRB



APPURTENANCE WALL

DRAWING NO.

W-16

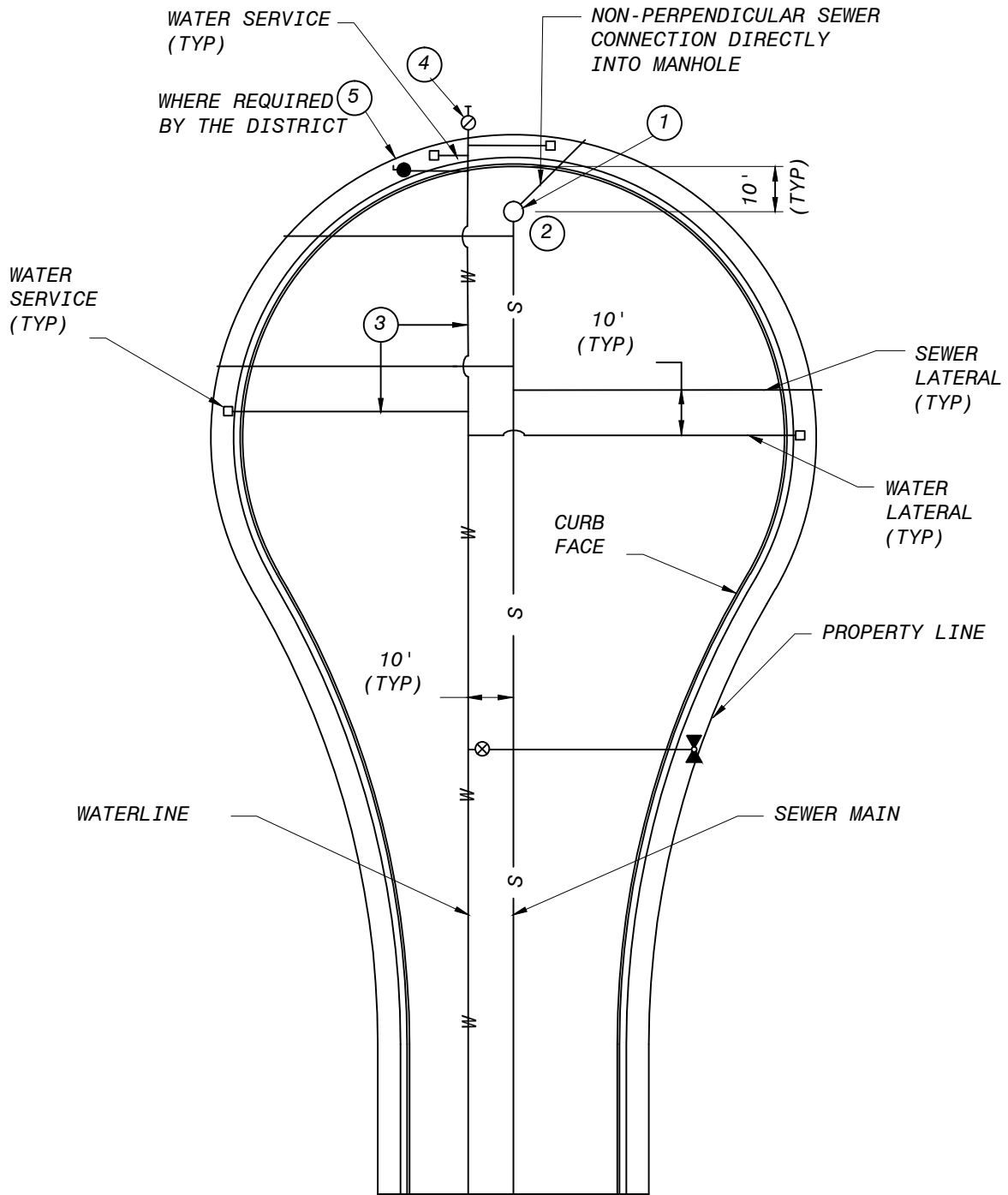

ITEM	DESCRIPTION
1	MANHOLE; USE WATER-TIGHT COVER WHERE CUL-DE-SAC CREATES LOW POINT
2	45° ANGLE ONLY IF NECESSARY TO SERVE REAR LOTS (WATER & SEWER)
3	90° ANGLE OFF MAINLINE (STANDARD FOR WATER & SEWER LATERALS)
4	END OF MAIN (BLOWOFF OR AAV). LOCATE TO CLEAR DRIVEWAYS
5	END OF MAIN AUTO AV/AR VALVE (WHERE CUL-DE-SAC CREATES A HIGH POINT).

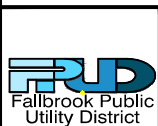

Rev. Date	By	APPRV'D
5/24/17	SMD	JRB



STANDARD CUL-DE-SAC
WATER LATERALS

DRAWING NO.

W-17

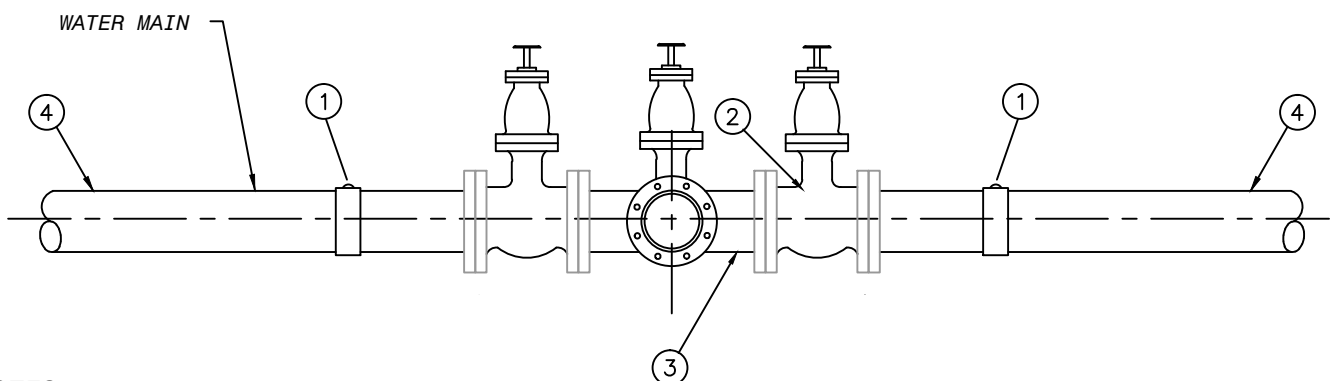
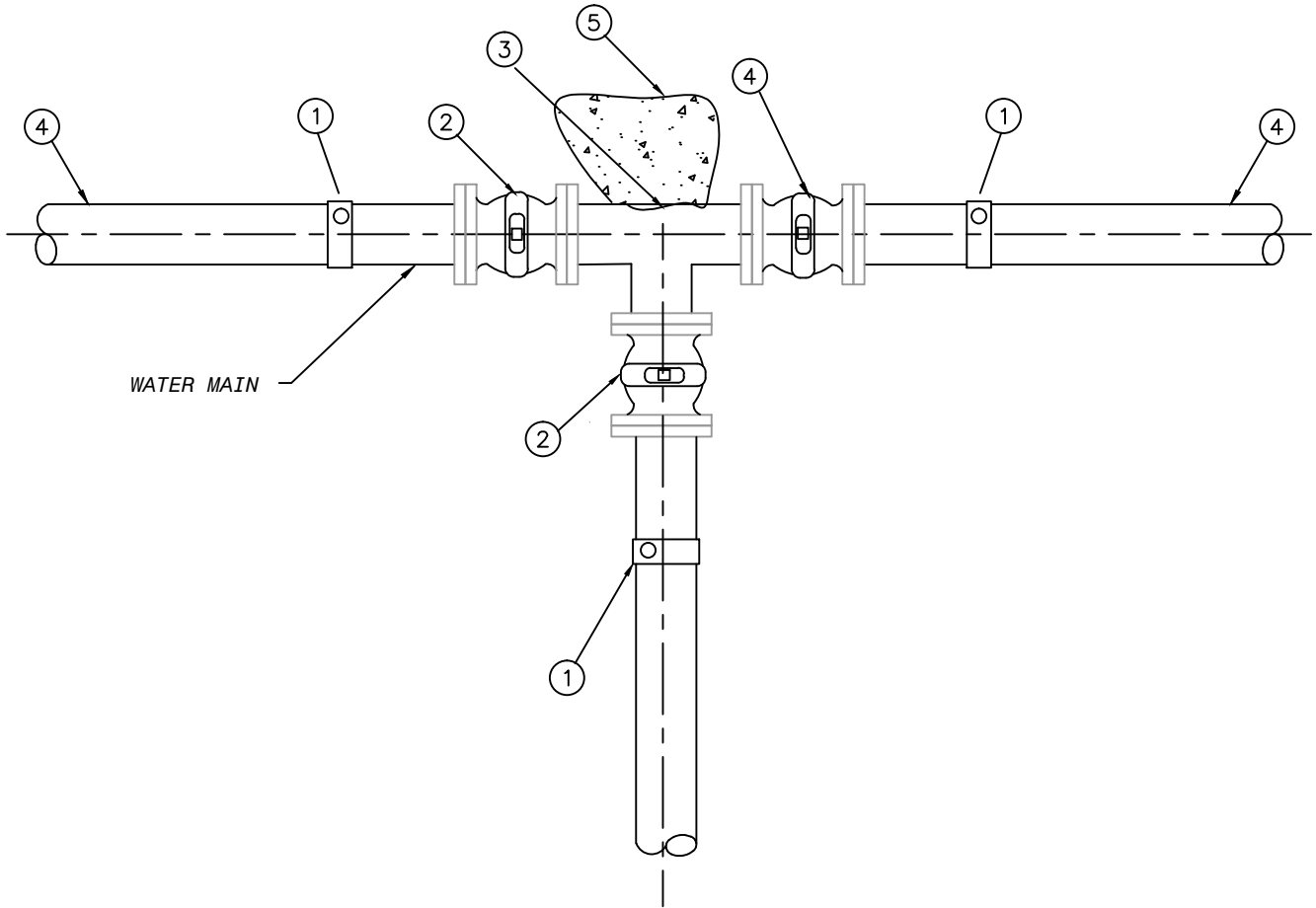

NOTES:

- 1) WRAP UNDERGROUND FACILITIES PER DISTRICT STANDARDS WITH 8 MIL POLYETHYLENE.
- 2) PIPE JOINTS SHALL BE ALL WELDED, WITH WELDED BUTT STRAPS, (1) - AS NEEDED.

- (1) BUTT STRAP W/ HANDHOLE
- (2) GATE VALVE
- (3) TEE
- (4) CML&C STEEL PIPE
- (5) THRUST BLOCK PER W-5

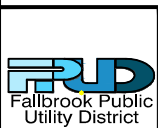

REV. DATE	BY	APPROVED
7/12/17	SMD	JRB



TYPICAL
THREE VALVE TEE

DRAWING NO.

W-18

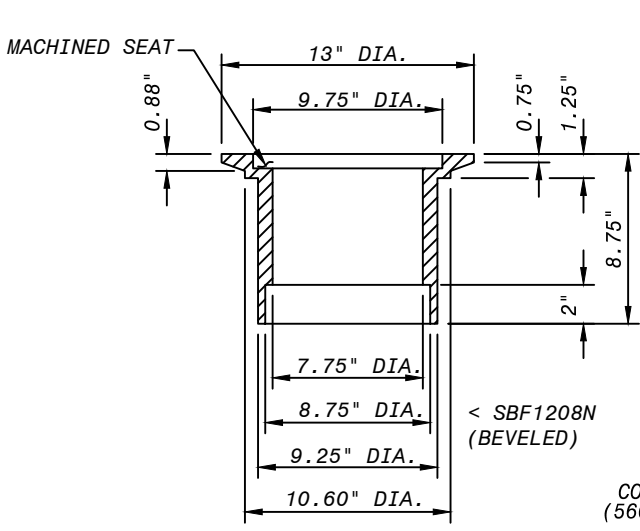

CAST IRON VALVE WELL FRAME

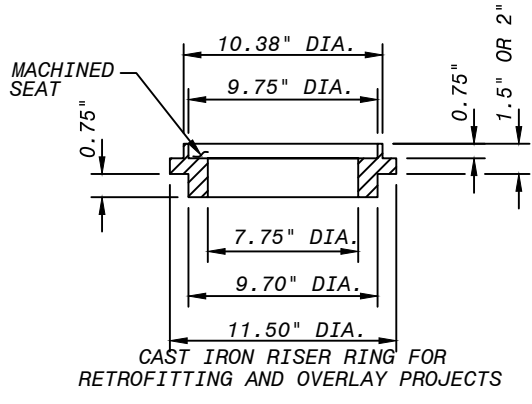

CAST IRON RISER RING FOR RETROFITTING AND OVERLAY PROJECTS

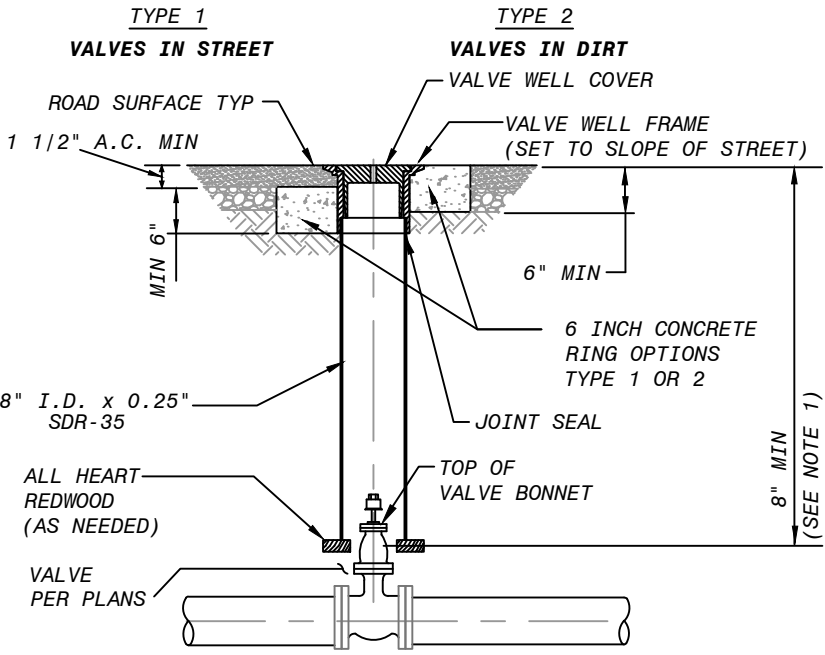
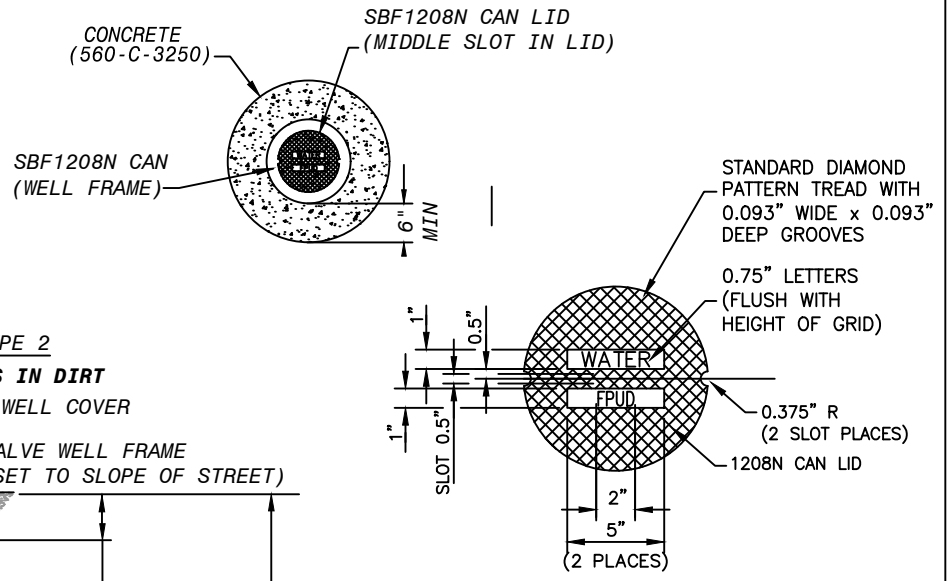

VALVE WELL AND FRAME FOR NEW INSTALLATIONS

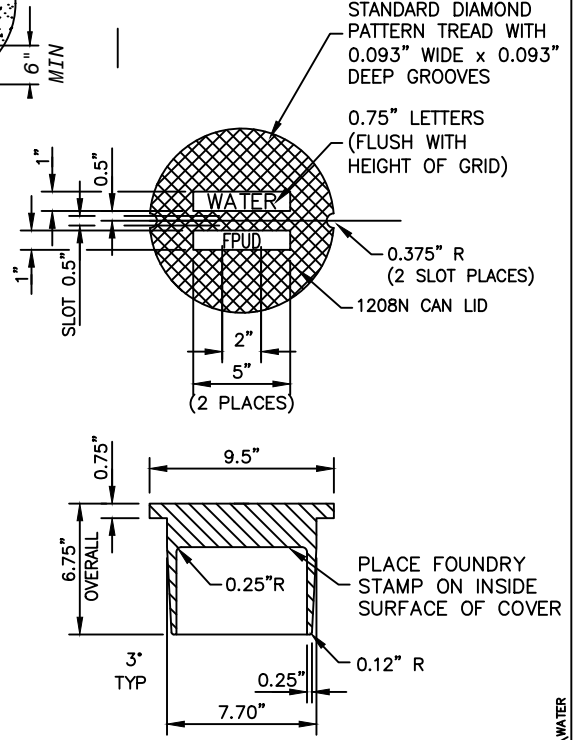

VALVE COVER / LID FOR NEW INSTALLATIONS

- NOTES:**
1. FOR GATE VALVES, PROVIDE VALVE KEY EXTENSION WHERE THIS DIMENSION EXCEEDS 60 INCHES. WHEN NEEDED, EXTENSIONS SHOULD RESULT IN VALVE NUTS BETWEEN 12 AND 14-INCHES DEEP FROM FINISH GRADE.
 2. THE SURFACE OF THE VALVE WELL COVER SHALL MATCH THE STREET CROSS SLOPE AND PROFILE.

VALVE COVER PAINT COLOR CHART:

ALL INLINE VALVES	SILVER
B.O.s, DRAINS, AIR VACS	SILVER
FIRE HYDRANTS	YELLOW
RECYCLED WATER	PURPLE
CLOSED INLINE VALVES	RED

11/3/21 - W-20 COMBINED WITH W-19



REV. DATE	BY	APPROVED
5/24/17	SMD	JRB
6/25/20	SMD	AWC
11/03/21	SMD	AWC

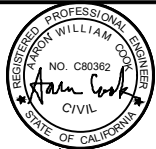

VALVE WELL FRAME AND VALVE WELL COVER

DRAWING NO.
W-19

X:\RECORD FILES\DISTRICT STANDARDS\DISTRICT DRAWINGS\WATER

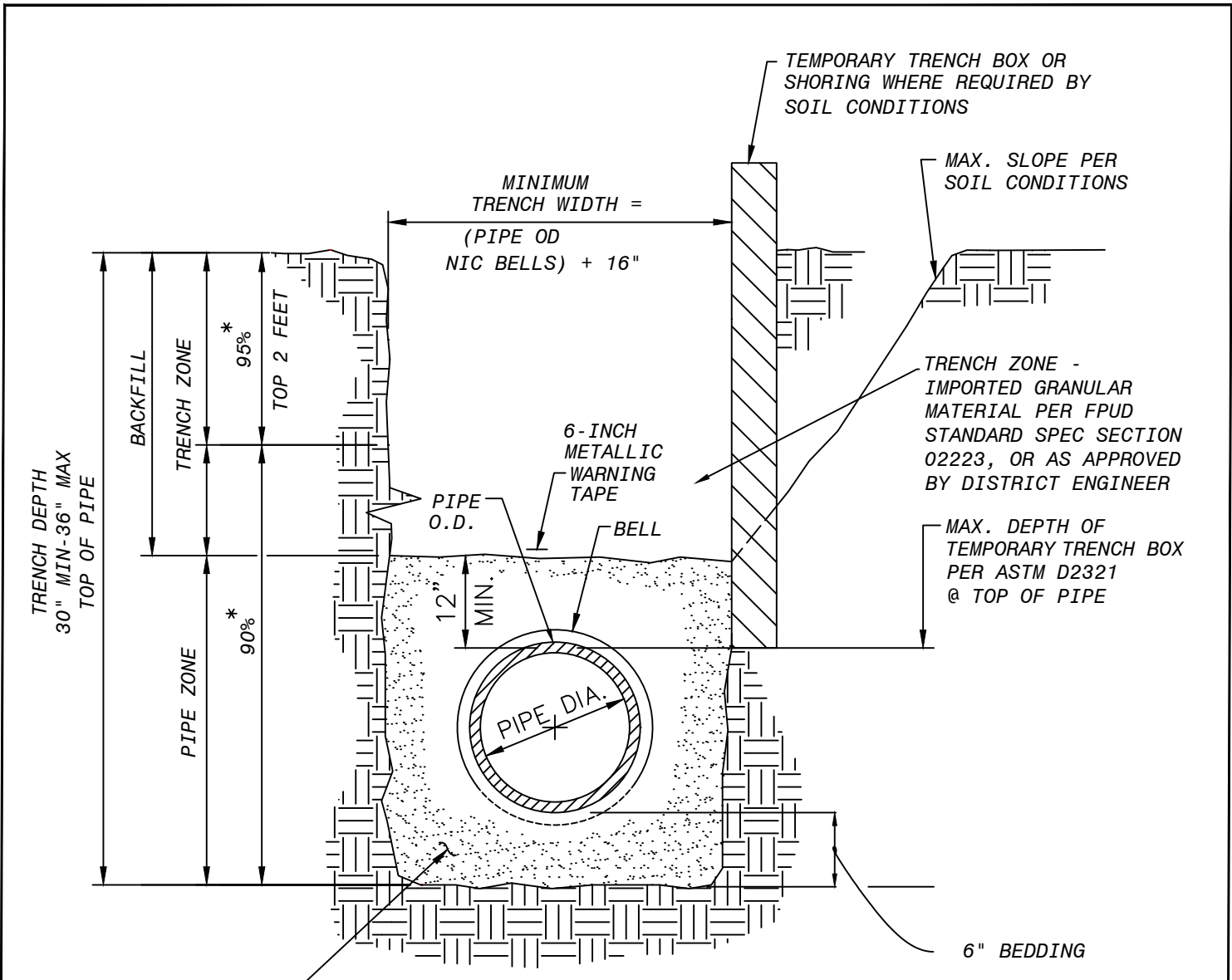

PIPE ZONE - IMPORTED GRANULAR MATERIAL PER FPUD STANDARD SPECIFICATION SECTION 02223, OR AS APPROVED BY DISTRICT ENGINEER

NOTES:

1. REFER TO SECTION 02223 OF THE SPECIFICATIONS
2. PAVING OR PAVEMENT REPAIR TO BE DONE IN ACCORDANCE TO COUNTY STANDARDS
3. EXCAVATE BELL HOLES AT EACH PIPE JOINT TO PERMIT PROPER ASSEMBLY AND INSPECTION OF THE ENTIRE JOINT.
4. (*) INDICATES MINIMUM RELATIVE COMPACTION. THE TOP 2 FEET, MINIMUM 95% COMPACTION, IS REQUIRED FOR ROADS.

11/3/21 - CHANGED TO W-20, WAS W-3

REV. DATE	BY	APPROVED
5/24/17	SMD	JRB
6/25/20	SMD	AWC
11/03/21	SMD	AWC

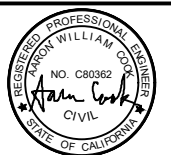

STANDARD PIPE ZONE AND TRENCH BACKFILL

DRAWING NO.

W-20

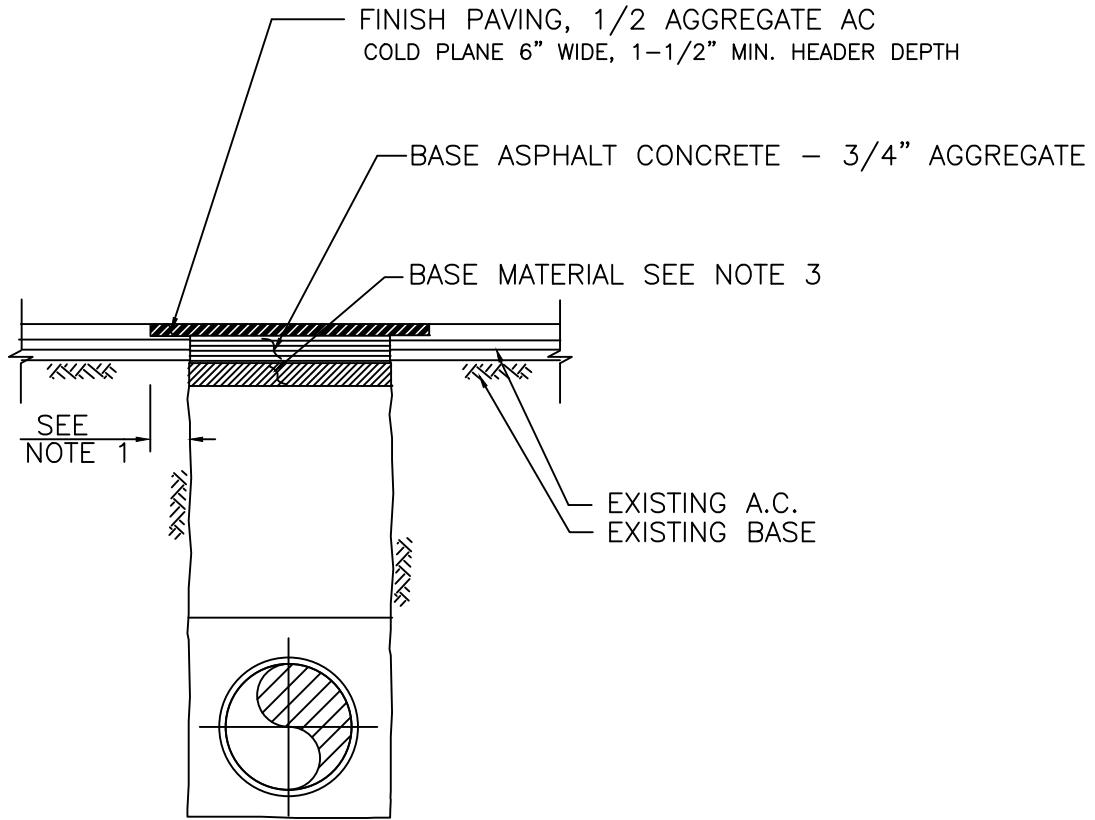

TYPE A

NOTES:

- 1) HEADER DEPTH OF 1.5" SHALL BE GRINDED FROM BASE PAVING AND EXISTING PAVING IN PREPARATION FOR FINISH PAVING LAYER OF 1/2" A.C. ASPHALT.
 - A) FOR TRENCHES LESS THAN 3 FEET HEADER GRIND SHALL BE 6-INCHES (MINIMUM) ON ALL EDGES.
 - B) FOR TRENCHES 3 FEET AND GREATER HEADER GRIND SHALL BE 12-INCHES (MINIMUM) ON ALL EDGES.
- 2) EXISTING A.S. SHALL BE CUT AND REMOVED IN SUCH A MANNER SO AS NOT TO TEAR, BULGE OR DISPLACE ADJACENT PAVEMENT. EDGES SHALL BE CLEAN AND VERTICAL. ALL CUTS SHALL BE PARALLEL OR PERPENDICULAR TO STREET CENTERLINE, WHEN PRACTICAL.
- 3) BASE MATERIAL TO BE PLACED TO DEPTH OF EXISTING BASE, OR 6-INCHES MINIMUM. A.C. MAY BE SUBSTITUTED FOR BASE MATERIAL. COMPACT TO 95%.
- 4) ASPHALT CONCRETE RESURFACING:
 - A) MINIMUM TOTAL THICKNESS SHALL BE 1-INCH GREATER THAN EXISTING A.C. OR 3-INCHES MINIMUM.
 - B) A.C. SHALL BE HOT PLANT MIX CALTRANS SPEC GRADE C2PG 64-10.
 - C) BASE PAVING SHALL BE 3/4" AGGREGATE. FINISH PAVING SHALL BE 1/2" AGGREGATE AND INSTALLED PER NOTE 1.
- 5) ALL A.C RESURFACING SHALL BE SEALED WITH AN EMULSIFIED ASPHALT AND COVERED WITH SAND. CHIP SEALING MAY BE APPLIED AS REQUIRED BY AGENCY.
- 6) SLOUGHING OF TRENCH UNDER PAVEMENT SHALL BE CAUSE FOR REQUIRING ADDITIONAL PAVEMENT AND BASE.
- 7) COUNTY ROADS SHALL BE PAVED ACCORDING TO SAN DIEGO COUNTY ROAD PAVING STANDARDS.

X:\RECORD FILES\DISTRICT STANDARDS\DISTRICT DRAWINGS\WATER

	Rev. Date	By	Apprv'd		TRENCH RESURFACING TYPE A	DRAWING NO.
	5/24/17	SMD	JRB			W-21
	6/25/20	SMD	AWC			
11/03/21	SMD	AWC				

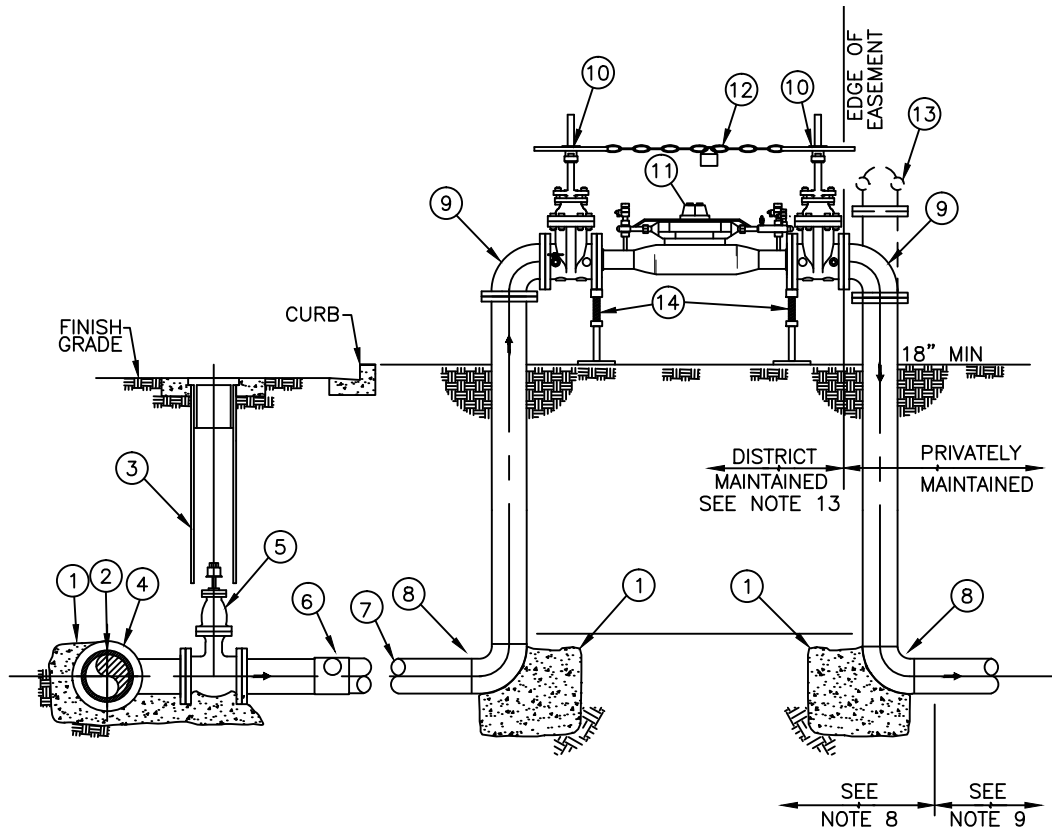

ITEM NO.	SIZE AND DESCRIPTION	ITEM NO.	SIZE AND DESCRIPTION	ITEM NO.	SIZE AND DESCRIPTION
①	CONCRETE THRUST BLOCK SEE W-4	⑥	WELDED BUTT-STRAP W/ HAND HOLE	⑪	3/4" BYPASS, RADIO READ METER & DOUBLE CHECK VALVE OR RP DEVICE
②	WATER MAIN	⑦	CML & C STEEL PIPE	⑫	CHAIN WITH LOCK SEE NOTE 4
③	GATE WELL SEE W-19	⑧	WELDED 90° BEND	⑬	FLANGED TEE WITH "FDC" SEE NOTE 4
④	SIZE X SIZE FLG X FLG TEE (WELDED)	⑨	FLANGED 90°	⑭	ADJUSTABLE VALVE SUPPORT
⑤	FLG X FLG RWGV	⑩	FLG'D OS&Y RWGV WITH HAND WHEEL		

- 1) REFER TO SECTION 15112 OF THE SPECIFICATIONS
- 2) INSTALL WARNING/IDENTIFICATION TAPE AS SHOWN ON W-3
- 3) LOCATION OF FIRE SERVICES SHALL BE AS DIRECTED BY THE FIRE DEPARTMENT OF JURISDICTION. FIRE SERVICES SHOULD BE LOCATED IN SUCH A MANNER THAT WILL ALLOW THE DEVICE TO BE READILY ACCESSIBLE FOR INSPECTION, REPAIR, AND USAGE.
- 4) TAMPER SWITCH, AUTOMATIC RESET, CHAIN WITH KNOX LOCK, AND FIRE DEPARTMENT CONNECTION ("FDC") SHALL BE AS REQUIRED BY THE FIRE DEPARTMENT OF JURISDICTION.
- 5) BALL VALVE TEST COCKS SHALL BE PROVIDED AND LOCATED PER THE MANUFACTURERS RECOMMENDATIONS AND THE REQUIREMENTS OF THE WATER AGENCY STANDARDS.
- 6) INSTALL FIRE SERVICES SO THAT THE DISTANCE BETWEEN THE BOTTOM OF THE RELIEF DIAPHRAGM AND THE CONCRETE SLAB OR FINISH GRADE IS 12" MIN. AND 36" MAX.
- 7) INSTALL AN ANGLE PRESSURE REDUCING VALVE IN LIEU OF THE FIRST 90° BEND WHEN SYSTEM STATIC PRESSURE EXCEEDS 175psi OR WHEN RECOMMENDED BY THE BACKFLOW MANUFACTURER
- 8) INSTALL PIPE AND RELATED APPURTENANCES IN THIS AREA PER THE REQUIREMENT OF THE FPUD SPECIFICATIONS.
- 9) INSTALL PIPE AND RELATED APPURTENANCES IN THIS AREA AS REQUIRED BE THE FIRE THE FIRE DEPARTMENT OF JURISDICTION.
- 10) ABOVE GROUND APPURTENANCE SHALL BE PAINTED AND IDENTIFIED AS CALLED FOR BY THE FIRE DEPARTMENT OF JURISDICTION.
- 11) TESTING SHALL BE CONDUCTED AS CALLED FOR IN SECTION 15112 OF THE SPECIFICATIONS PRIOR TO ACCEPTANCE BY THE DISTRICT.
- 12) MATERIALS SHALL BE SELECTED FORM THE APPROVED MATERIALS LIST.
- 13) DISTRICT RESPONSIBILITY ENDS AT THE DOWNSTREAM SIDE OF THE VALVE.

	Rev.Date	By	Apprv'd		4" AND LARGER FIRE SERVICE INSTALLATION	DRAWING NO.
	5/24/17	SMD	JRB			W-22

ELEVATION

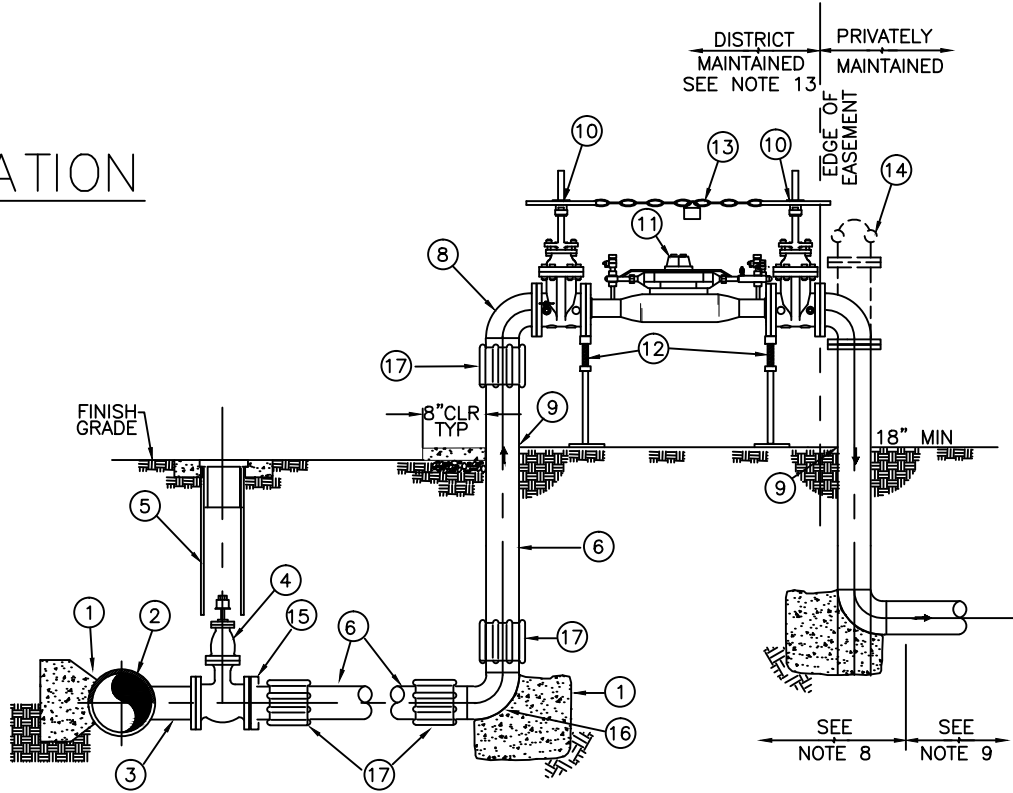

MATERIAL LIST

ITEM NO.	SIZE AND DESCRIPTION	ITEM NO.	SIZE AND DESCRIPTION	ITEM NO.	SIZE AND DESCRIPTION
①	THRUST BLOCK, FPUD SEC. 03300	⑦	DELETED	⑬	CHAIN WITH LOCK
②	WELD SADDLE	⑧	3"x90° DI PIPE ELBOW, MJxFLG	⑭	FIRE DEPARTMENT CONNECTION
③	3" FLANGED OUTLET/ AWWA & DISTRICT STANDARDS	⑨	WRAP FOAM TAPE FOR CONCRETE PENETRATION	⑮	MJxFLG ADAPTER
④	3" FLGxFLG RWGV (PLUG V. ≥ 250 PSI)	⑩	FLANGED OS&Y RWGV W/ HAND WHEEL	⑯	3"x90° DIA PIPE ELBOW, MJxMJ
⑤	VALVE WELL, W-19	⑪	3/4" BYPASS RADIO READ METER & DCV/RP DEVICE	⑰	MEGA-LUG RESTRAINT
⑥	3" DI PIPE T.2E.	⑫	ADJUSTABLE VALVE SUPPORT		

NOTES:

- 1) REFER TO SECTION 15112 OF THE SPECIFICATIONS
- 2) INSTALL WARNING/IDENTIFICATION TAPE AS SHOWN ON W-3
- 3) LOCATION OF FIRE SERVICES SHALL BE AS DIRECTED BY THE FIRE DEPARTMENT OF JURISDICTION. FIRE SERVICES SHOULD BE LOCATED IN SUCH A MANNER THAT WILL ALLOW THE DEVICE TO BE READILY ACCESSIBLE FOR INSPECTION, REPAIR, AND USAGE.
- 4) TAMPER SWITCH, AUTOMATIC RESET, CHAIN WITH KNOX LOCK, AND FIRE DEPARTMENT CONNECTION ("FDC") SHALL BE AS REQUIRED BY THE FIRE DEPARTMENT OF JURISDICTION.
- 5) BALL VALVE TEST COCKS SHALL BE PROVIDED AND LOCATED PER THE MANUFACTURES RECOMMENDATIONS AND THE REQUIREMENTS OF THE WATER AGENCY STANDARDS.
- 6) INSTALL FIRE SERVICES SO THAT THE DISTANCE BETWEEN THE BOTTOM OF THE RELIEF DIAPHRAGM AND THE CONCRETE SLAB OR FINISH GRADE IS 12" MIN. AND 36" MAX.
- 7) INSTALL AN ANGLE PRESSURE REDUCING VALVE IN LIEU OF THE FIRST 90° BEND WHEN SYSTEM STATIC PRESSURE EXCEEDS 175psi OR WHEN RECOMMENDED BY THE BACKFLOW MANUFACTURER
- 8) INSTALL PIPE AND RELATED APPURTENANCES IN THIS AREA PER THE REQUIREMENT OF THE FPUD SPECIFICATIONS.
- 9) INSTALL PIPE AND RELATED APPURTENANCES IN THIS AREA AS REQUIRED BE THE FIRE THE FIRE DEPARTMENT OF JURISDICTION.
- 10) ABOVE GROUND APPURTENANCE SHALL BE PAINTED AND IDENTIFIED AS CALLED FOR BY THE FIRE DEPARTMENT OF JURISDICTION.
- 11) TESTING SHALL BE CONDUCTED AS CALLED FOR IN SECTION 15112 OF THE SPECIFICATIONS PRIOR TO ACCEPTANCE BY THE DISTRICT.
- 12) MATERIALS SHALL BE SELECTED FORM THE APPROVED MATERIALS LIST.
- 13) DISTRICT RESPONSIBILITY ENDS AT DOWNSTREAM SIDE OF VALVE.



Rev.Date	By	Apprv'd
5/24/17	SMD	JRB



3" FIRE SERVICE INSTALLATION

DRAWING NO.

W-23

ELEVATION

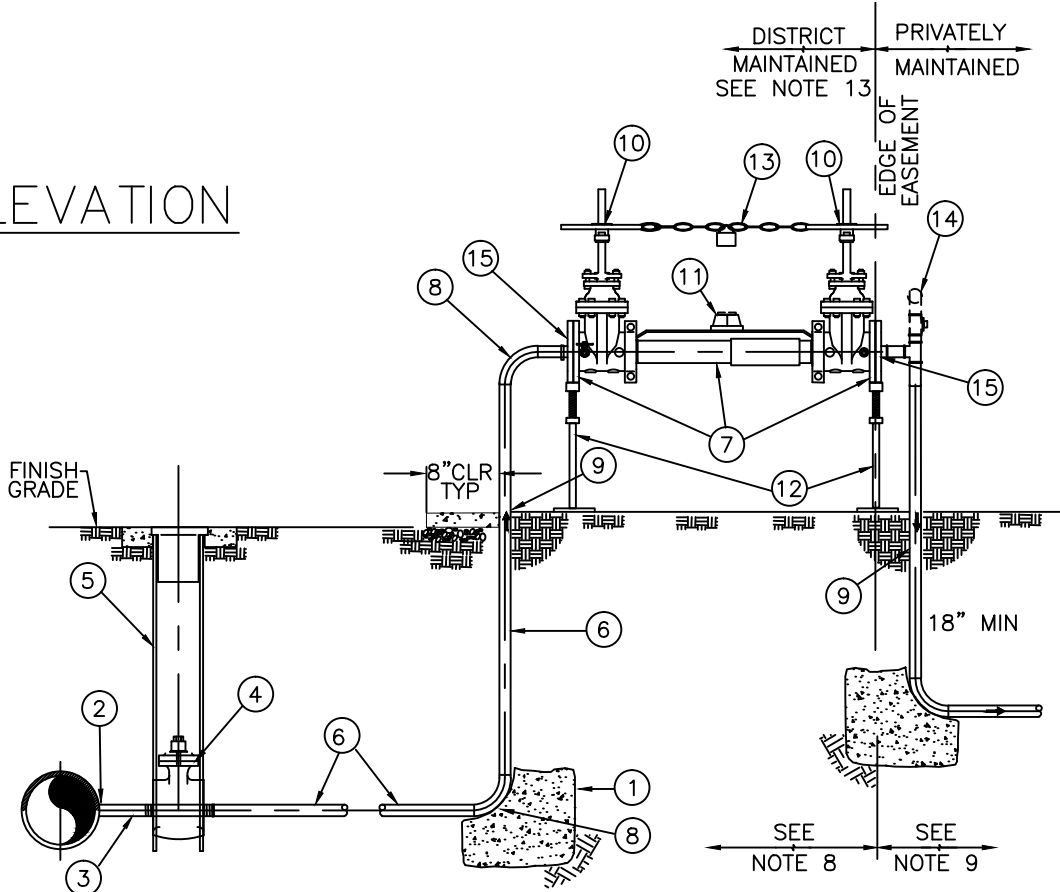

MATERIAL LIST

ITEM NO.	SIZE AND DESCRIPTION	ITEM NO.	SIZE AND DESCRIPTION	ITEM NO.	SIZE AND DESCRIPTION
①	THRUST BLOCK, FPUD SEC. 03300	⑥	2" RIGID COPPER PIPE	⑪	3/4" BYPASS RADIO READ METER & RP DEVICE (LEAK DETECTOR)
②	WELD SADDLE - PER W-5 AWWA & DISTRICT STANDARDS	⑦	2-1/2" DCDA COLT 300-GV ASSEMBLY BY AMES COMP.	⑫	ADJUSTABLE VALVE SUPPORTS
③	2" FIP COPPER / 12-INCH NIPPLE.	⑧	2"x90° COPPER ELBOW, SOLDERED	⑬	CHAIN WITH LOCK
④	2" FIPxFIP PLUG VALVE	⑨	WRAP FOAM TAPE FOR CONCRETE PENETRATION	⑭	FIRE DEPARTMENT CONNECTION FITTINGS WITH SHUTOFF VALVE
⑤	VALVE WELL, W-19	⑩	FLANGED OS&Y RWGV W/ HAND WHEEL	⑮	2-1/2" X 2" FIP FLANGE ADAPTER

NOTES:

- 1) REFER TO SECTION 15112 OF THE SPECIFICATIONS
- 2) INSTALL WARNING/IDENTIFICATION TAPE AS SHOWN ON W-3, STANDARD PIPE ZONE & TRENCH BACKFILL.
- 3) LOCATION OF FIRE SERVICES SHALL BE AS DIRECTED BY THE FIRE DEPARTMENT OF JURISDICTION. FIRE SERVICES SHOULD BE LOCATED IN SUCH A MANNER THAT WILL ALLOW THE DEVICE TO BE READILY ACCESSIBLE FOR INSPECTION, REPAIR, AND USAGE.
- 4) TAMPER SWITCH, AUTOMATIC RESET, CHAIN WITH KNOX LOCK, AND FIRE DEPARTMENT CONNECTION ("FDC") SHALL BE AS REQUIRED BY THE FIRE DEPARTMENT OF JURISDICTION.
- 5) BALL VALVE TEST COCKS SHALL BE PROVIDED AND LOCATED PER THE MANUFACTURES RECOMMENDATIONS AND THE REQUIREMENTS OF THE WATER AGENCY STANDARDS.
- 6) INSTALL FIRE SERVICES SO THAT THE DISTANCE BETWEEN THE BOTTOM OF THE RELIEF DIAPHRAGM AND THE CONCRETE SLAB OR FINISH GRADE IS 12" MIN. AND 36" MAX.
- 7) INSTALL AN ANGLE PRESSURE REDUCING VALVE IN LIEU OF THE FIRST 90° BEND WHEN SYSTEM STATIC PRESSURE EXCEEDS 175psi OR WHEN RECOMMENDED BY THE BACKFLOW MANUFACTURER
- 8) INSTALL PIPE AND RELATED APPURTENANCES IN THIS AREA PER THE REQUIREMENT OF THE FPUD SPECIFICATIONS.
- 9) INSTALL PIPE AND RELATED APPURTENANCES IN THIS AREA AS REQUIRED BE THE FIRE THE FIRE DEPARTMENT OF JURISDICTION.
- 10) ABOVE GROUND APPURTENANCE SHALL BE PAINTED AND IDENTIFIED AS CALLED FOR BY THE FIRE DEPARTMENT OF JURISDICTION.
- 11) TESTING SHALL BE CONDUCTED AS CALLED FOR IN SECTION 15112 OF THE SPECIFICATIONS PRIOR TO ACCEPTANCE BY THE DISTRICT.
- 12) MATERIALS SHALL BE SELECTED FORM THE APPROVED MATERIALS LIST.
- 13) DISTRICT RESPONSIBILITY ENDS AT DOWNSTREAM SIDE OF VALVE.
- 14) ALL UNDERGROUND PIPE SHALL BE WRAPPED IN POLY SLEEVE AND / OR TAPED WITH 10 MIL PVC TAPE.

	Rev.Date	By	Apprv'd		2" FIRE SERVICE INSTALLATION	DRAWING NO.
	2/07/18	SMD	JRB			W-24

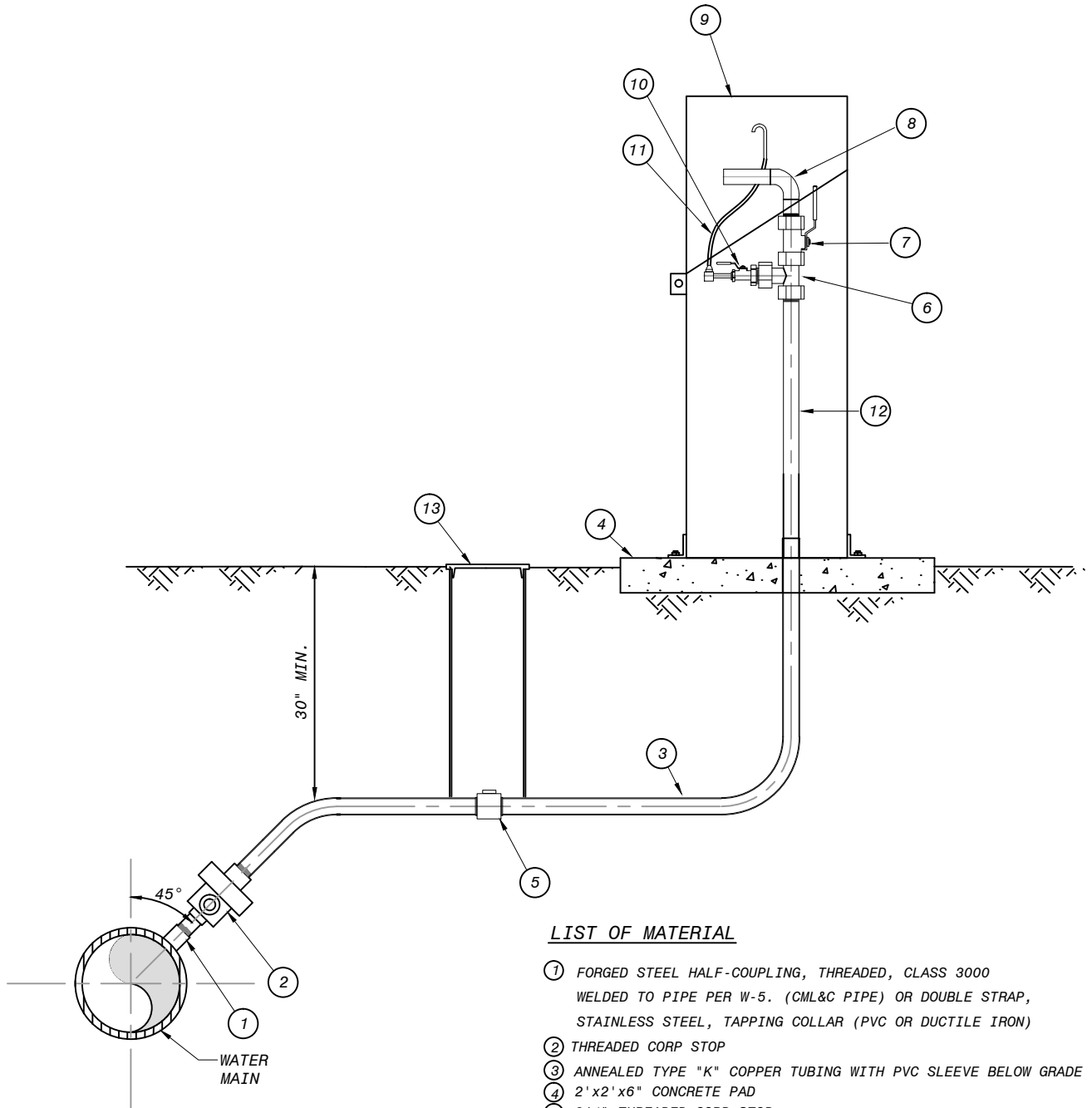

LIST OF MATERIAL

- ① FORGED STEEL HALF-COUPLING, THREADED, CLASS 3000 WELDED TO PIPE PER W-5. (CML&C PIPE) OR DOUBLE STRAP, STAINLESS STEEL, TAPPING COLLAR (PVC OR DUCTILE IRON)
- ② THREADED CORP STOP
- ③ ANNEALED TYPE "K" COPPER TUBING WITH PVC SLEEVE BELOW GRADE
- ④ 2' x 2' x 6" CONCRETE PAD
- ⑤ 3/4" THREADED CORP STOP
- ⑥ 3/4" x 3/4" x 3/4" TEE
- ⑦ 3/4" THREADED GLOBE VALVE
- ⑧ 3/4" FLUSHING COPPER TUBING
- ⑨ 8" DIA. STEEL CASING, BOLTED TO PAD
- ⑩ 1/8" GLOBE VALVE
- ⑪ 1/8" BENT COPPER TUBING
- ⑫ 3/4" BRASS NIPPLE
- ⑬ VALVE CAN



REV	BY	APRVD
2016		JB



WATER SAMPLE STATION

DRAWING NO.

W-25

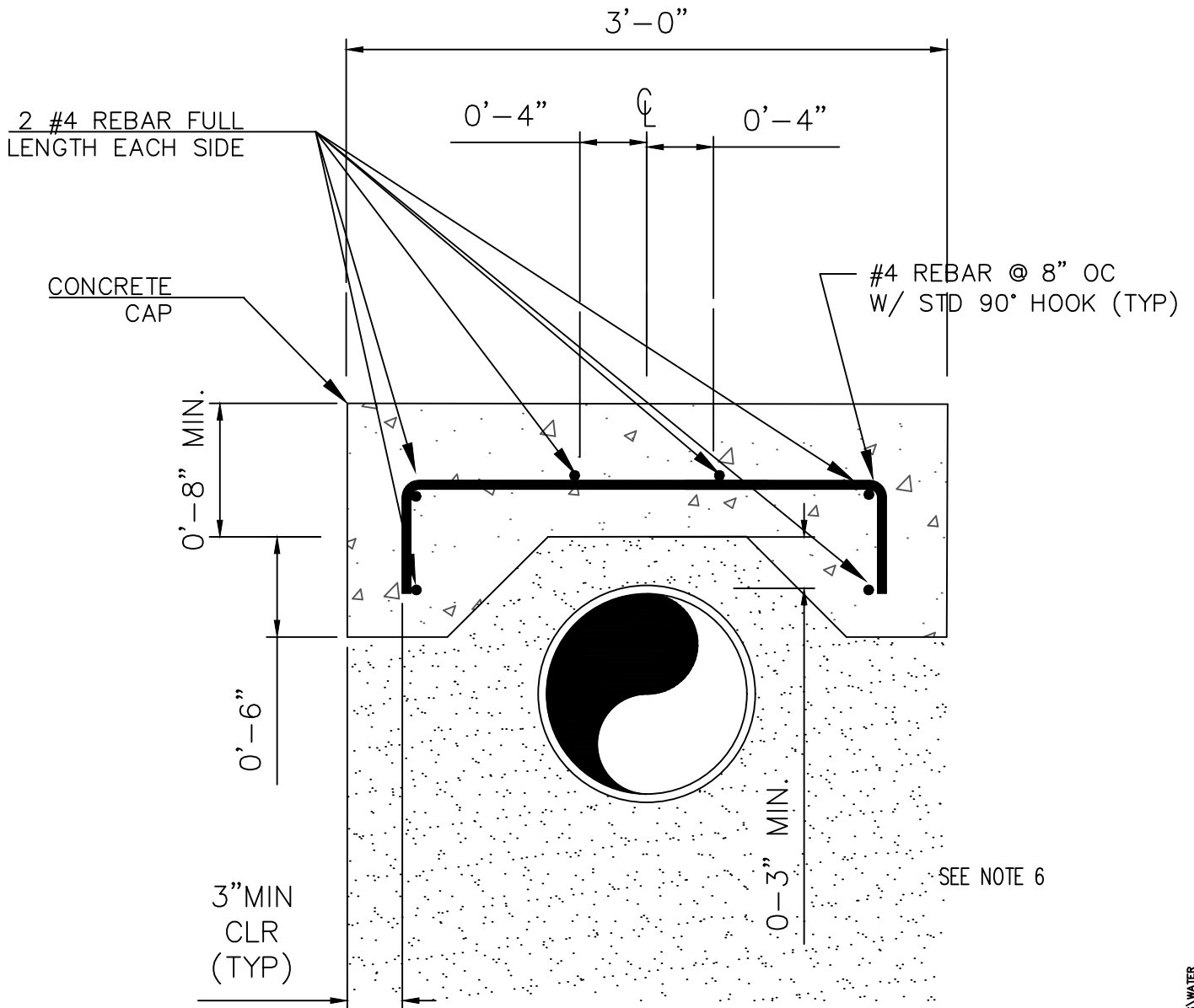

NOTES

- 1) CAP SHALL BE OF CLASS "A" CONCRETE.
- 2) REBAR SHALL HAVE YIELD STRENGTH OF 60KSI
- 3) CONCRETE CAP SHALL BE USED FOR SHALLOW PIPE INSTALLATIONS 24-INCHES OR LESS; AS DIRECTED BY DISTRICT ENGINEER.
- 4) COVER WITH ASPHALT PAVING, 6" MINIMUM.
- 5) REBAR SHALL HAVE 3" CLEARANCE, MINIMUM, ALL SIDES.
- 6) NOTE SPECIFIED PIPE BEDDING PER TRENCH DETAIL, W-20, AND DISTRICT ENGINEER.

X:\RECORD FILES\DISTRICT STANDARDS\DISTRICT DRAWINGS\WATER



Rev.Date	By	Apprv'd
11/3/21	SMD	AWC



CONCRETE CAP

DRAWING NO.

W-26